

P-19716

S6347

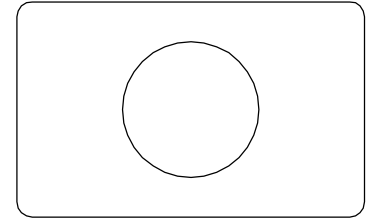

1:1

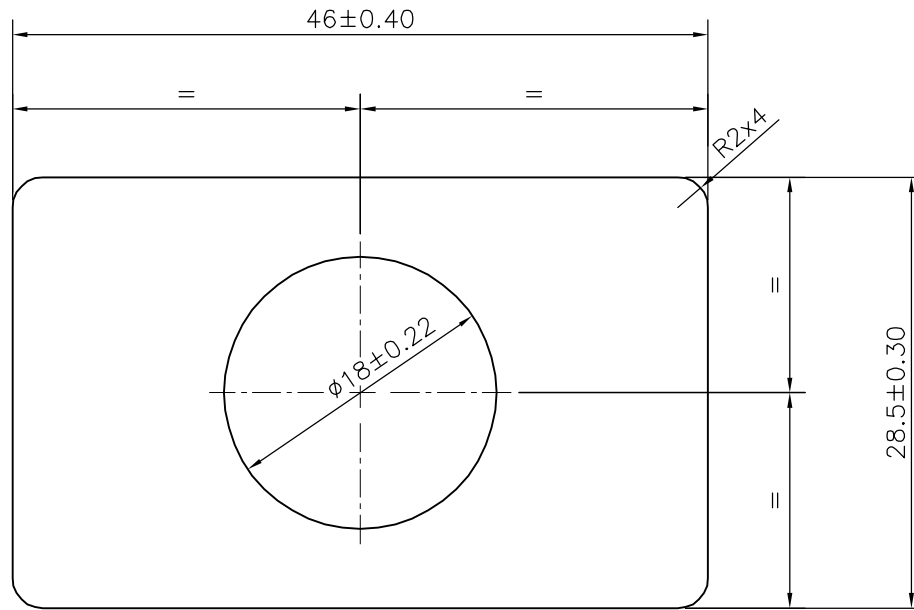

SYMBOL OF QUALITY
AN ISO 9001 COMPANY

JINDAL ALUMINIUM LTD.
BANGALORE-560073 (INDIA)

	NAME	DATE
DRAWN	J.P.KAUSHIK	24-06-2019
CHECKED		
APPROVED	B.NATARAJA	08-07-2019
SCALE		2:1
AREA mm ²		1053.097
PERIMETER mm.		145.566
WEIGHT kg/m		2.843
DRAWING No.	SECTION No.	
P-19716	-	
S6347	S6347	

1. ALL DIMENSIONS ARE IN mm.
2. ROUND OFF ALL SHARP CORNERS WITH 0.40 mm.
3. TOLERANCES WILL BE AS PER IS:6477-1983 , UNLESS OTHERWISE SPECIFIED

PARTY'S NAME	SHANMUGHA PRECISION FORGING, THANJAVUR
PARTY'S DRAWING No.	10632229/AD
ALLOY & TEMPER	6063 T6
DESCRIPTION	MISC. SECTION