

P-19658

S6374

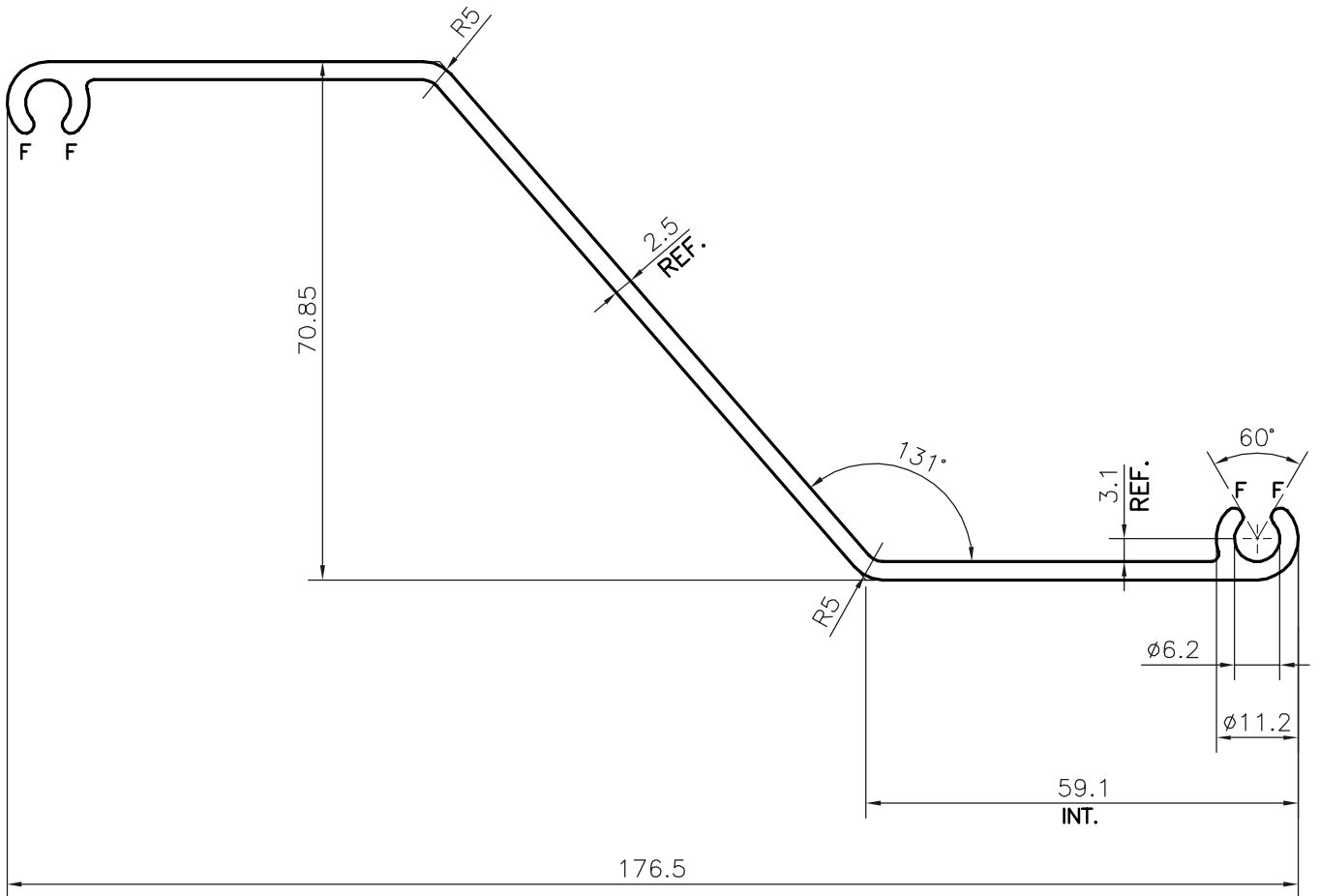

F = FULL RADIUS (4 PLACES)



SYMBOL OF QUALITY
AN ISO 9001 COMPANY

JINDAL ALUMINIUM LTD.
BANGALORE-560073 (INDIA)

	NAME	DATE
DRAWN	DARPAN	14-06-2019
CHECKED		
APPROVED	B.NATARAJA	06-08-2019
SCALE		1:1
AREA mm ²		585.743
PERIMETER mm.		466.034
WEIGHT kg/m		1.582
DRAWING No.	SECTION No.	
P-19658	-	
S6374	S6374	

1. ALL DIMENSIONS ARE IN mm.
2. ROUND OFF ALL SHARP CORNERS WITH 0.40 mm.
3. TOLERANCES WILL BE AS PER IS:3965-1981 , UNLESS OTHERWISE SPECIFIED

PARTY'S NAME	PANCHSHIL REALTY AND DEVELOPERS PVT LTD., PUNE
PARTY'S DRAWING No.	AS PER AUTOCAD DRAWING
ALLOY & TEMPER	6063 T6
DESCRIPTION	LOUVER SECTION