

P-19941

S6375

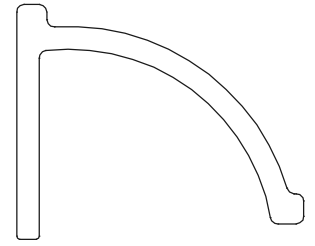

SCALE: - 1:1

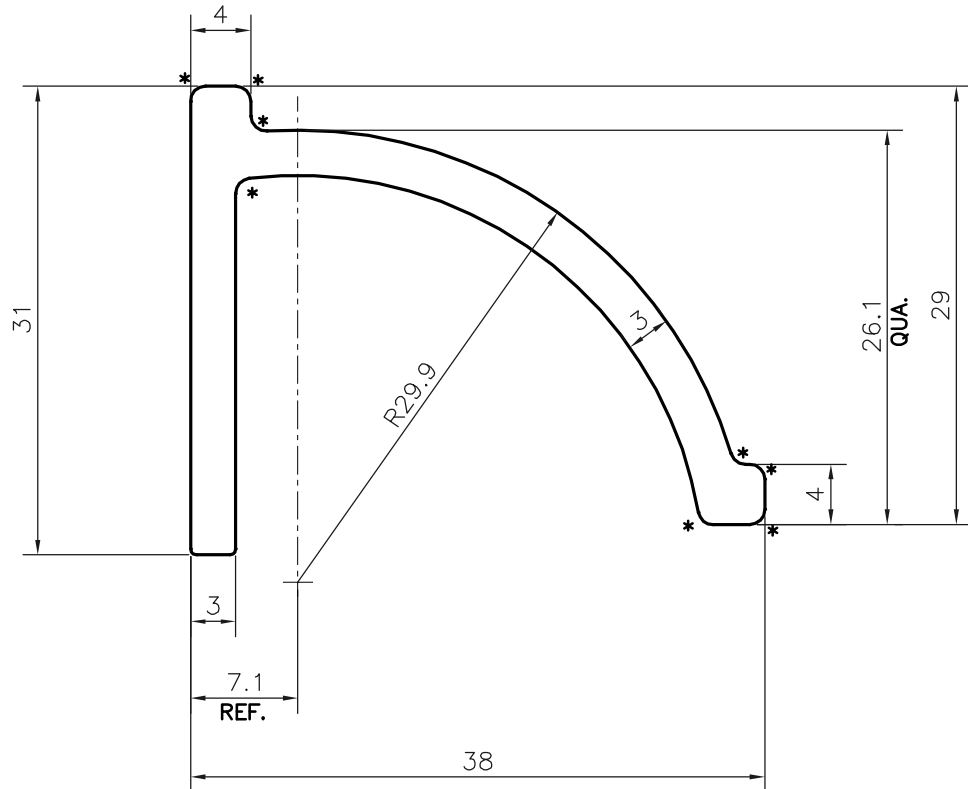

\* = R1 (8 PLACES)



SYMBOL OF QUALITY  
AN ISO 9001 COMPANY

**JINDAL ALUMINIUM LTD.**  
BANGALORE-560073 (INDIA)

	NAME	DATE
DRAWN	DARPAN	01-08-2019
CHECKED		
APPROVED	B.NATARAJA	06-08-2019
SCALE		2:1
AREA mm <sup>2</sup>		236.676
PERIMETER mm.		157.487
WEIGHT kg/m		0.639
DRAWING No.	SECTION No.	
P-19941	-	
S6375	S6375	

1. ALL DIMENSIONS ARE IN mm.
2. ROUND OFF ALL SHARP CORNERS WITH 0.40 mm.
3. TOLERANCES WILL BE AS PER IS:3965-1981 , UNLESS OTHERWISE SPECIFIED

PARTY'S NAME	PUSHPAK PRODUCT (INDIA) PVT. LTD. (BANGALORE)
PARTY'S DRAWING No.	AS PER AUTOCAD DRAWING
ALLOY & TEMPER	6063 T6
DESCRIPTION	MISC. SECTION