

P-19714-1

S6379

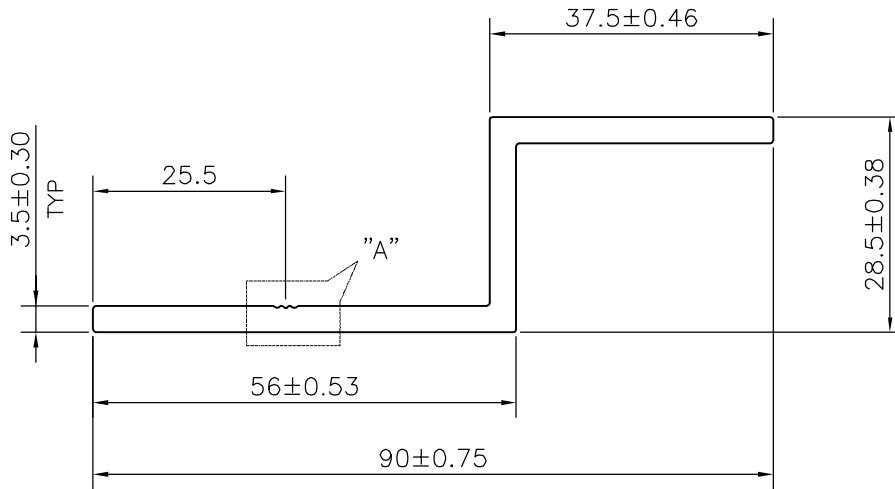
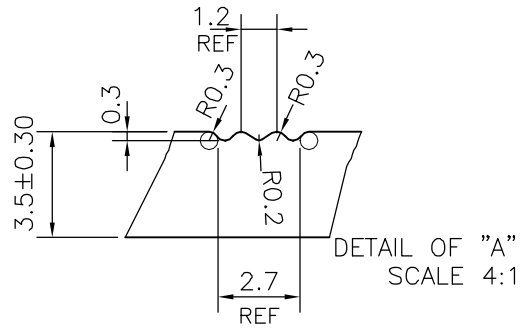

SYMBOL OF QUALITY  
AN ISO 9001 COMPANY

**JINDAL ALUMINIUM LTD.**  
BANGALORE-560073 (INDIA)

	NAME	DATE
DRAWN	J.P.KAUSHIK	05-07-2019
CHECKED		
APPROVED	B.NATARAJA	06-08-2019

1. ALL DIMENSIONS ARE IN mm.
2. ROUND OFF ALL SHARP CORNERS WITH 0.40 mm.
3. TOLERANCES WILL BE AS PER IS:3965-1981 , UNLESS OTHERWISE SPECIFIED

SCALE	1:1
AREA mm <sup>2</sup>	401.873
PERIMETER mm.	236.226
WEIGHT kg/m	1.085

PARTY'S NAME	SWASTIK FENESTRATION WORLD, NAVI MOMBAI
PARTY'S DRAWING No.	AS PER DRAWING
ALLOY & TEMPER	6063 T6
DESCRIPTION	Z SECTION

DRAWING No.	SECTION No.
P-19714-1	-
S6379	S6379