

P-19715-1

S6380

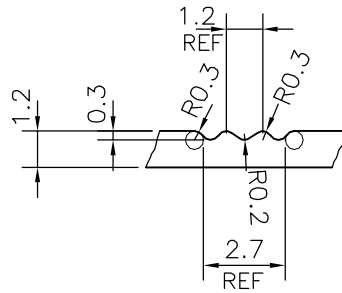

1:1



DETAIL OF "A"
SCALE 4:1

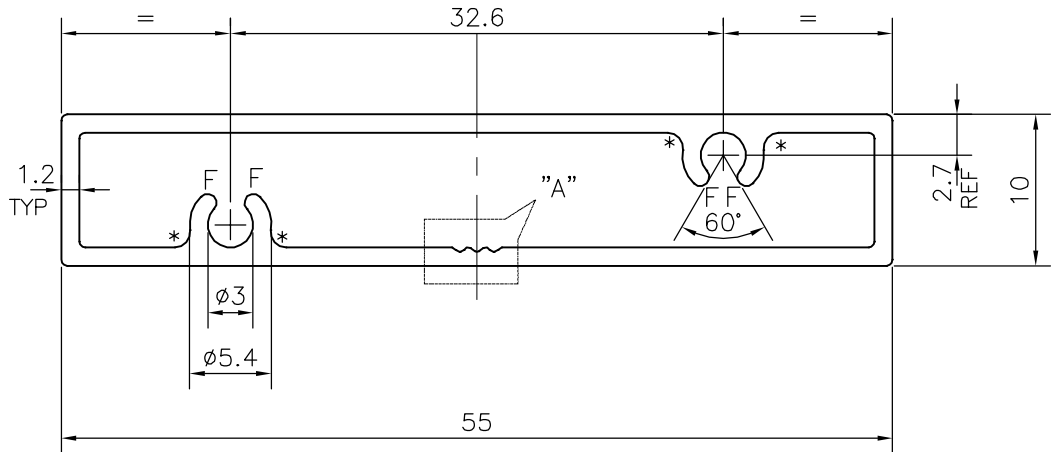

F = FULL RADIUS (4 PLACES)

* = 1.0 RADIUS (4 PLACES)



SYMBOL OF QUALITY
AN ISO 9001 COMPANY

JINDAL ALUMINIUM LTD.
BANGALORE-560073 (INDIA)

	NAME	DATE
DRAWN	J.P.KAUSHIK	28-06-2019
CHECKED		
APPROVED	B.NATARAJA	06-08-2019
SCALE		2:1
AREA	mm ²	169.472
PERIMETER	mm.	129.313
WEIGHT	kg/m	0.458
DRAWING No.	SECTION No.	
P-19715-1	-	
S6380	S6380	

1. ALL DIMENSIONS ARE IN mm.
2. ROUND OFF ALL SHARP CORNERS WITH 0.40 mm.
3. TOLERANCES WILL BE AS PER IS:6477-1983 , UNLESS OTHERWISE SPECIFIED

PARTY'S NAME	SWASTIK FENESTRATION WORLD, NAVI MOMBAI
PARTY'S DRAWING No.	AS PER DRAWING
ALLOY & TEMPER	6063 T6
DESCRIPTION	RECTANGULAR TUBE-MISC.