

P-19749-1

S6381

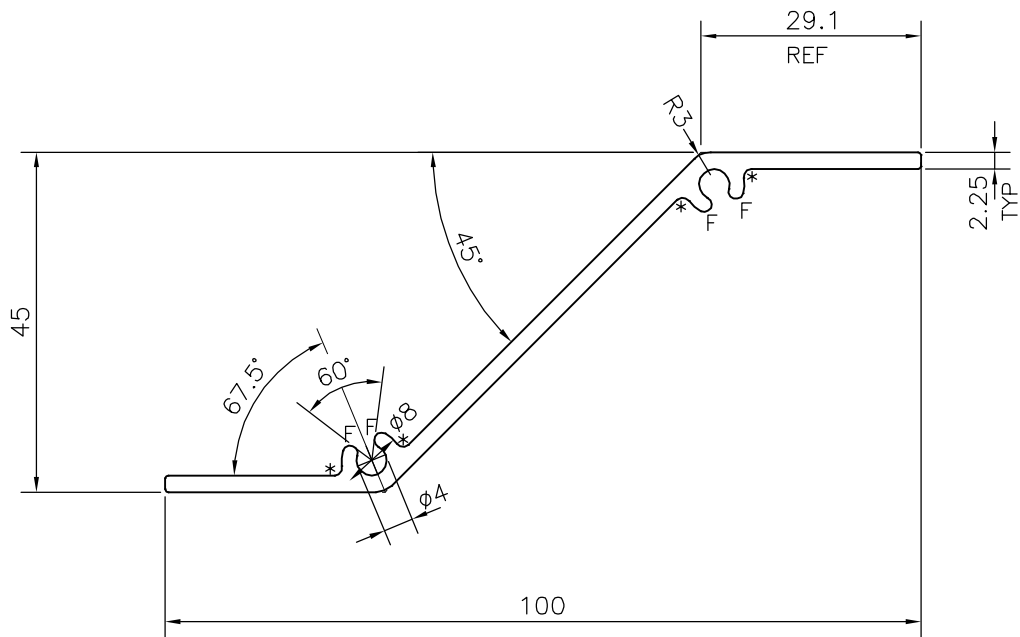

F = FULL RADIUS (4 PLACES)

\* = 1.0 RADIUS (4 PLACES)



SYMBOL OF QUALITY  
AN ISO 9001 COMPANY

**JINDAL ALUMINIUM LTD.**  
BANGALORE-560073 (INDIA)

	NAME	DATE
DRAWN	J.P.KAUSHIK	05-07-2019
CHECKED		
APPROVED	B.NATARAJA	06-08-2019

1. ALL DIMENSIONS ARE IN mm.
2. ROUND OFF ALL SHARP CORNERS WITH 0.40 mm.
3. TOLERANCES WILL BE AS PER IS:3965-1981 , UNLESS OTHERWISE SPECIFIED

SCALE	1:1
AREA mm <sup>2</sup>	298.051
PERIMETER mm.	262.197
WEIGHT kg/m	0.805

PARTY'S NAME	SWASTIK FENESTRATION WORLD, NAVI MOMBAI	DRAWING No.	P-19749-1	SECTION No.	-
PARTY'S DRAWING No.	AS PER DRAWING & REQUIREMENT		S6381		S6381
ALLOY & TEMPER	6063 T6				
DESCRIPTION	LOUVER SECTION				