

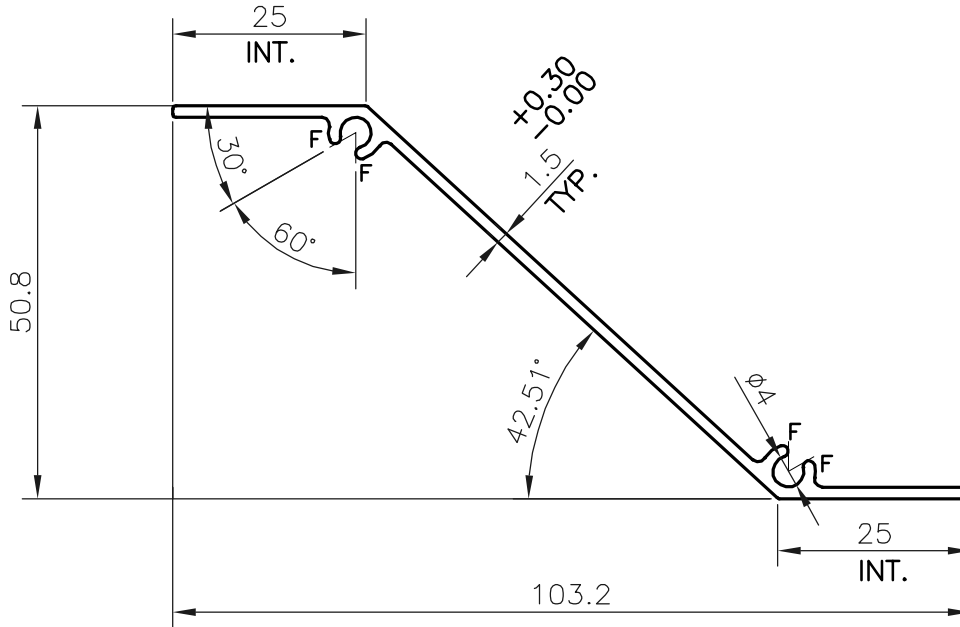

P-19952

S6387



F = FULL RADIUS (4 PLACES)

PLEASE SPECIFY THE EXPOSED SURFACE IN THE DRAWING WHEREVER BETTER FINISH REQUIRED.

 SYMBOL OF QUALITY AN ISO 9001 COMPANY	JINDAL ALUMINIUM LTD. BANGALORE-560073 (INDIA)	NAME	DATE
		DRAWN	DARPAN 03-08-2019
1. ALL DIMENSIONS ARE IN mm. 2. ROUND OFF ALL SHARP CORNERS WITH 0.40 mm. 3. TOLERANCES WILL BE AS PER IS:3965-1981, UNLESS OTHERWISE SPECIFIED		CHECKED	
		APPROVED	B.NATARAJA 07-08-2019
PARTY'S NAME ALUFIT (INDIA) PRIVATE LIMITED, BANGALORE		SCALE	1:1
		AREA mm ²	209.359
PARTY'S DRAWING No. HEAVIER OF SECTION 21150		PERIMETER mm.	270.452
		WEIGHT kg/m	0.565
ALLOY & TEMPER 6063 T6		DRAWING No.	SECTION No.
		P-19952	-
DESCRIPTION LOUVER SECTION		S6387	S6387