

P-19754-1

S6392

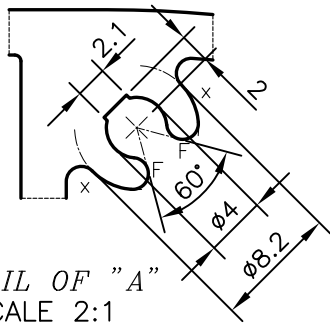

DETAIL OF "A"
SCALE 2:1

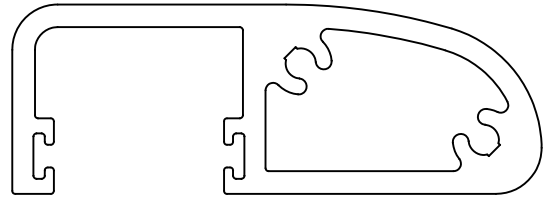

SCALE: - 1:1

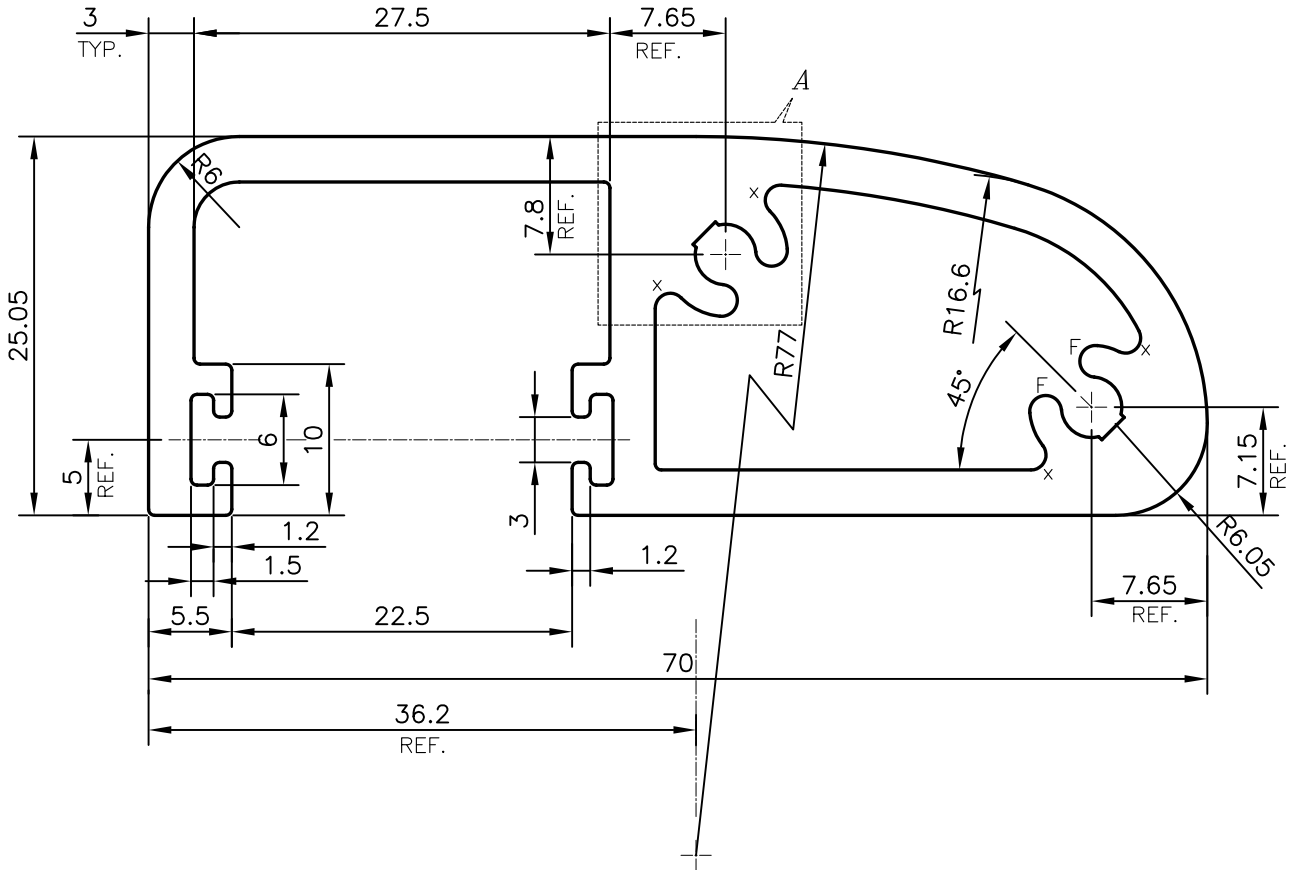

F = FULL RADIUS (4 PLACES)
X = RADIUS 1 mm. (4 PLACES)

TOLERANCES ON OVERALL WIDTHS & WIDTHS ACROSS FLATS OF BARS, & REGULAR SECTIONS

UPTO 6.40mm - ±0.20	UPTO 32.0mm - ±0.38	UPTO 120.0mm - ±0.85	1. STRAIGHTNESS=1.7 mm/M 2. TWIST=1.7 mm/M 3. ANGULARITY= ±2° 4. FLATNESS =0.007xWIDTH
UPTO 10.0mm - ±0.23	UPTO 50.0mm - ±0.46	UPTO 160.0mm - ±1.02	
UPTO 12.0mm - ±0.25	UPTO 60.0mm - ±0.53	UPTO 200.0mm - ±1.14	
UPTO 16.0mm - ±0.28	UPTO 80.0mm - ±0.69	UPTO 250.0mm - ±1.40	
UPTO 25.0mm - ±0.30	UPTO 100.0mm - ±0.75	UPTO 300.0mm - ±1.65	



SYMBOL OF QUALITY
AN ISO 9001 COMPANY

JINDAL ALUMINIUM LTD.
BANGALORE-560073 (INDIA)

	NAME	DATE
DRAWN	PARVESH	05-08-2019
CHECKED		
APPROVED	B.NATARAJA	07-08-2019
SCALE		2:1
AREA mm ²		583.673
PERIMETER mm.		247.036
WEIGHT kg/m		1.576
DRAWING No.	SECTION No.	
P-19754-1	-	
S6392	S6392	

- ALL DIMENSIONS ARE IN mm.
- ROUND OFF ALL SHARP CORNERS WITH 0.40 mm.
- TOLERANCES WILL BE AS PER IS:6477-1983, UNLESS OTHERWISE SPECIFIED

PARTY'S NAME	ALUPLEX INDIA PVT. LTD., MUMBAI
PARTY'S DRAWING No.	AS PER AUTOCAD DRAWING-AP-1963
ALLOY & TEMPER	6063 T6
DESCRIPTION	CURTAIN WALL SECTION-AL-44