

P-19786-2

S6407

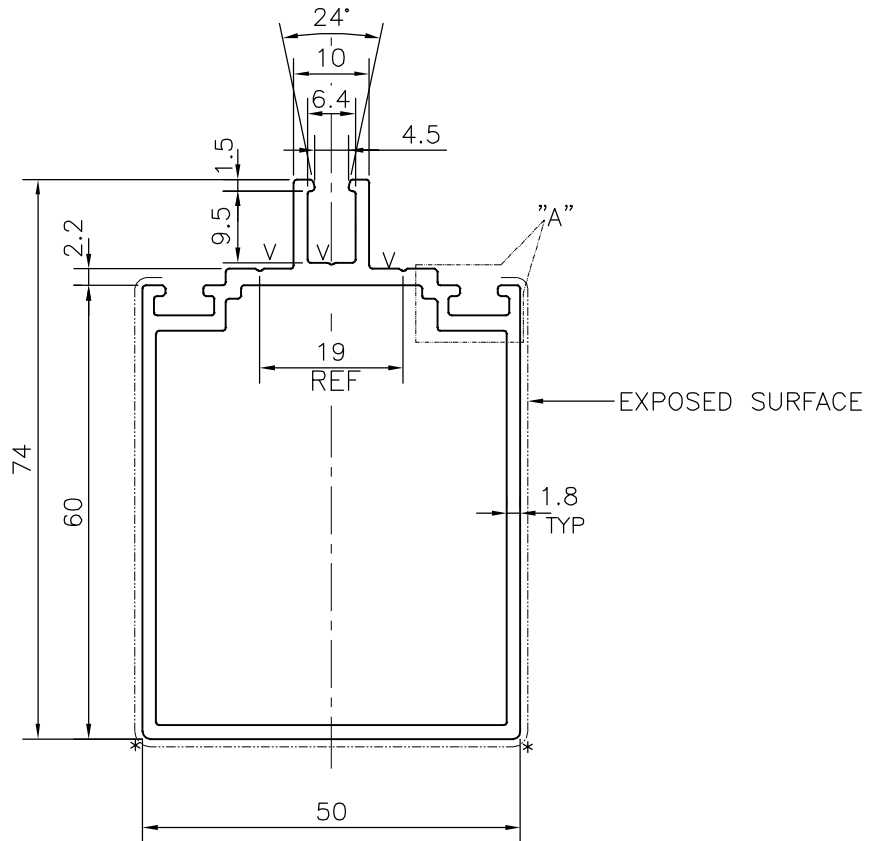
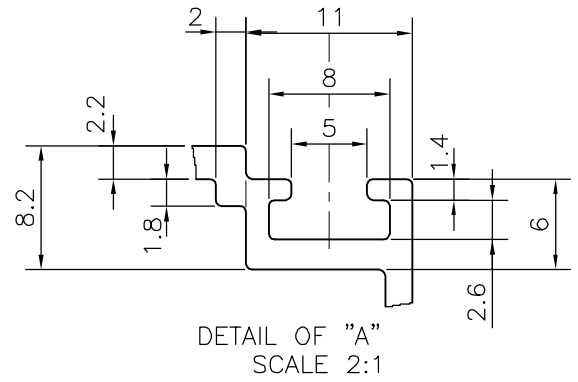

V = V GROOVE 0.3x90° (3 PLACES)

* = 1.0 RADIUS (2 PLACES)



SYMBOL OF QUALITY
AN ISO 9001 COMPANY

JINDAL ALUMINIUM LTD.
BANGALORE-560073 (INDIA)

	NAME	DATE
DRAWN	J.P.KAUSHIK	01-08-2019
CHECKED		
APPROVED	B.NATARAJA	07-08-2019
SCALE		1:1
AREA mm ²		472.496
PERIMETER mm.		295.403
WEIGHT kg/m		1.276
DRAWING No.	SECTION No.	
P-19786-2	-	
S6407	S6407	

1. ALL DIMENSIONS ARE IN mm.
2. ROUND OFF ALL SHARP CORNERS WITH 0.40 mm.
3. TOLERANCES WILL BE AS PER IS:6477-1983 , UNLESS OTHERWISE SPECIFIED

PARTY'S NAME	CITY CORPORATION LTD., PUNE
PARTY'S DRAWING No.	AS PER DRAWING
ALLOY & TEMPER	6063 T6
DESCRIPTION	CURTAIN WALL SECTION