

P-19805

S6417

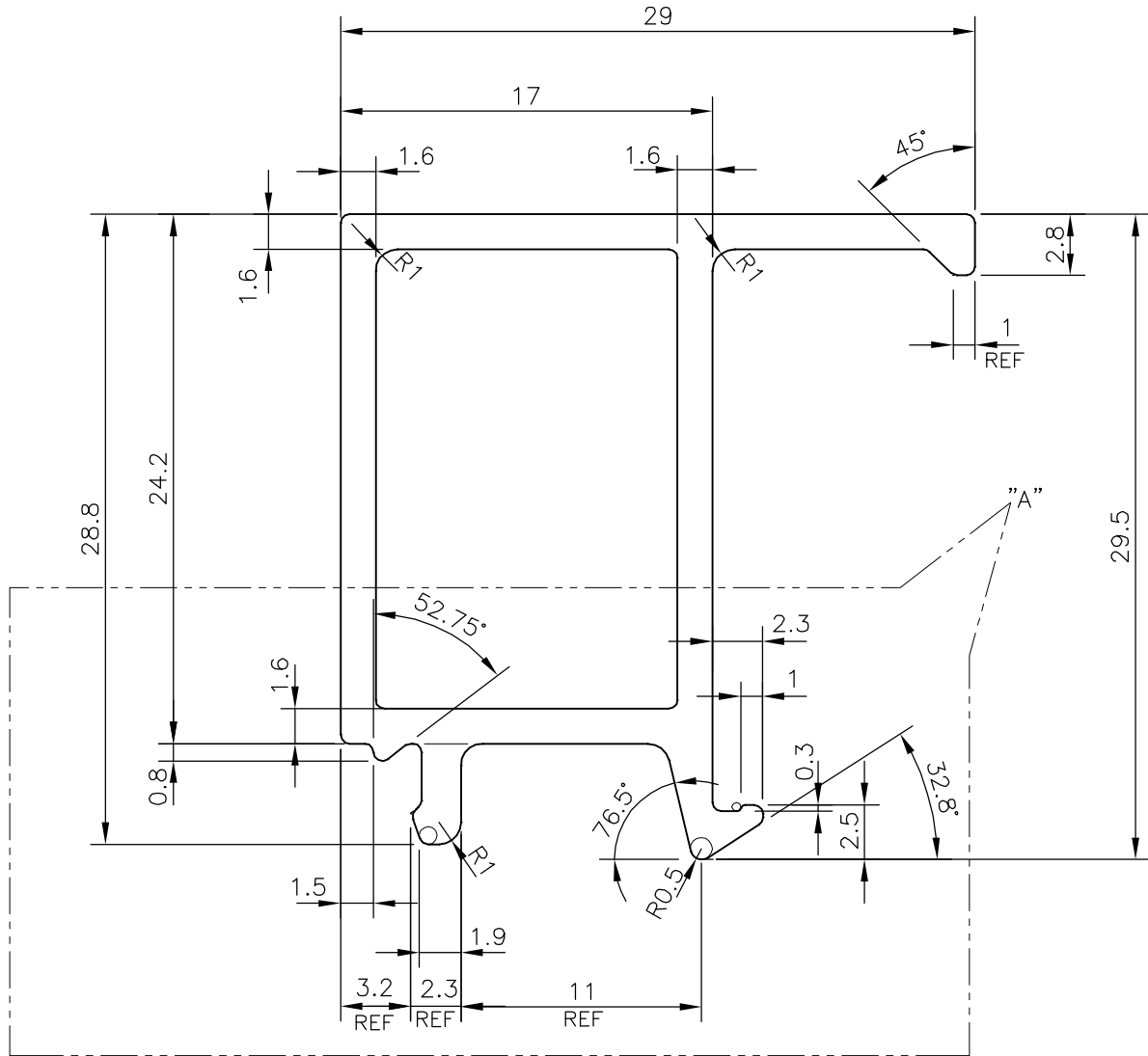
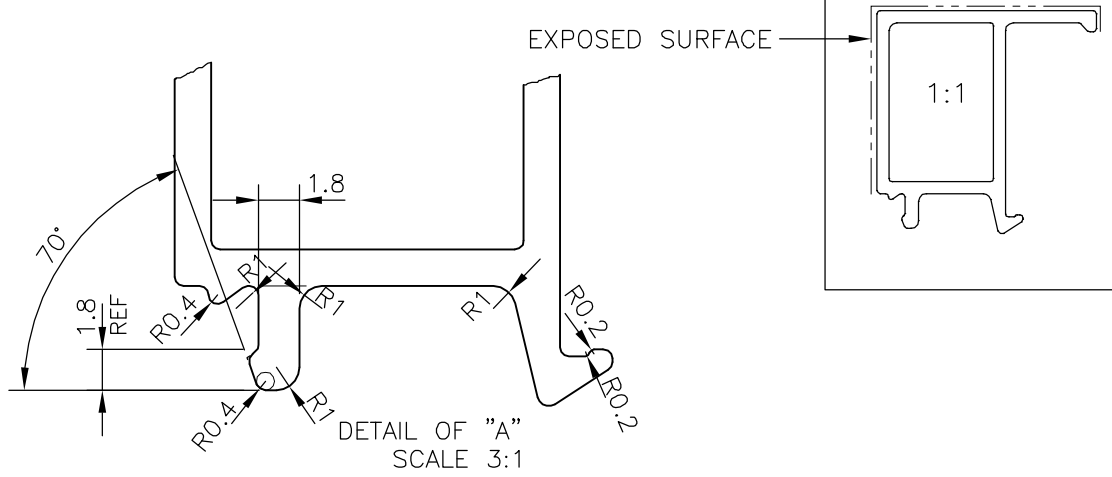

SYMBOL OF QUALITY
AN ISO 9002 COMPANY

JINDAL ALUMINIUM LTD.
BANGALORE-560073 (INDIA)

	NAME	DATE
DRAWN	J.P.KAUSHIK	06-07-2019
CHECKED		
APPROVED	B.NATARAJA	07-08-2019
SCALE		3:1
AREA mm ²		163.974
PERIMETER mm.		128.523
WEIGHT kg/m		0.443
DRAWING No.	SECTION No.	
P-19805	-	
S6417	S6417	

1. ALL DIMENSIONS ARE IN mm.
2. ROUND OFF ALL SHARP CORNERS WITH 0.40 mm.
3. TOLERANCES WILL BE AS PER IS:6477-1983 UNLESS OTHERWISE SPECIFIED

PARTY'S NAME	CITY CORPORATION LTD., PUNE
PARTY'S DRAWING No.	AS PER DRAWING
ALLOY & TEMPER	6063 T6
DESCRIPTION	BEADING (OPENABLE)