

P-19949

S6426

1:1

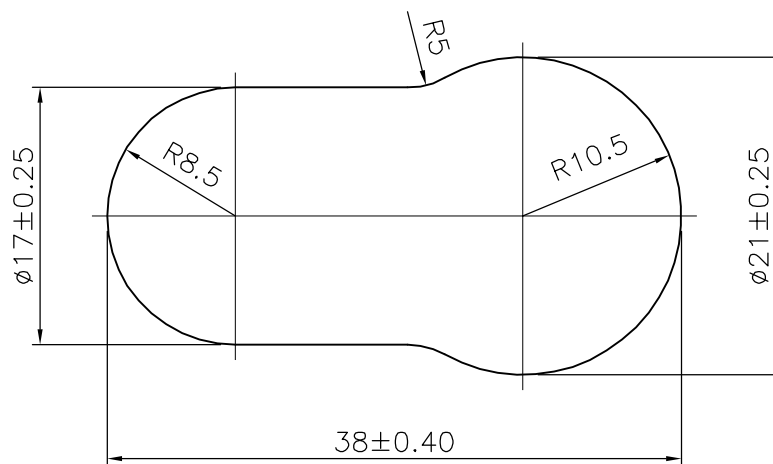

SYMBOL OF QUALITY
AN ISO 9001 COMPANY

JINDAL ALUMINIUM LTD.
BANGALORE-560073 (INDIA)

	NAME	DATE
DRAWN	J.P.KAUSHIK	03-08-2019
CHECKED		
APPROVED	B.NATARAJA	09-08-2019
SCALE		2:1
AREA mm ²		626.802
PERIMETER mm.		98.381
WEIGHT kg/m		1.692
DRAWING No.		SECTION No.
P-19949		-
S6426		S6426

1. ALL DIMENSIONS ARE IN mm.
2. ROUND OFF ALL SHARP CORNERS WITH 0.40 mm.
3. TOLERANCES WILL BE AS PER IS:3965-1981 , UNLESS OTHERWISE SPECIFIED

PARTY'S NAME S.S INDUSTRIES, BANGALORE

PARTY'S DRAWING No. 446251-5030

ALLOY & TEMPER DA3103 BDO

DESCRIPTION TUBE CONNECTOR SECTION