

P-19977

S6454

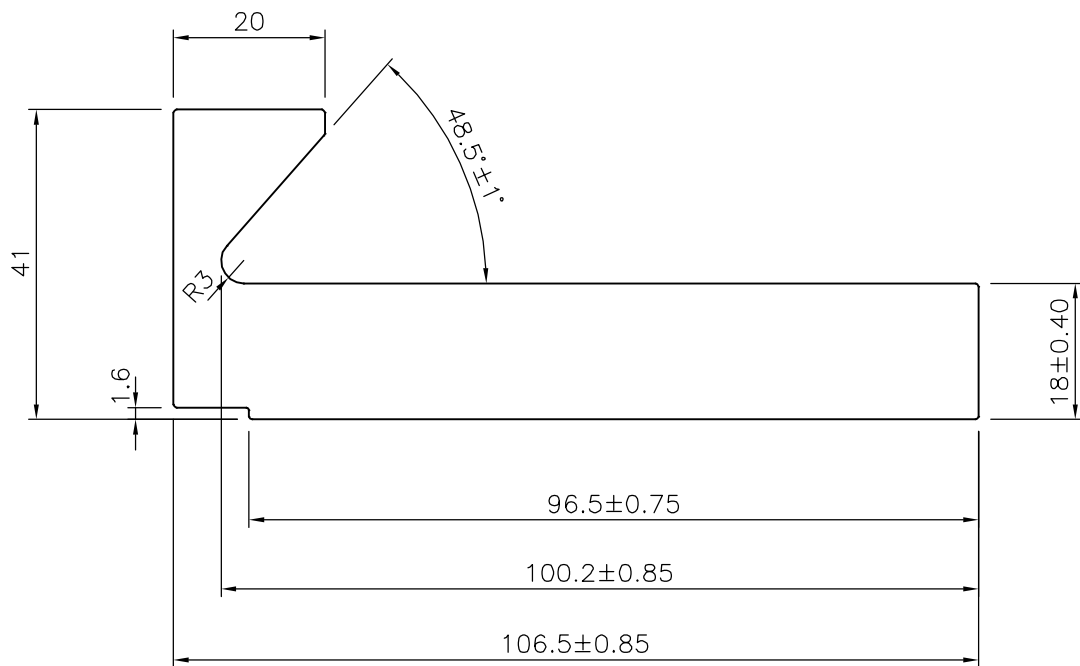

SYMBOL OF QUALITY
AN ISO 9001 COMPANY

JINDAL ALUMINIUM LTD.
BANGALORE-560073 (INDIA)

| | NAME | DATE |
|----------------------|-------------|------------|
| DRAWN | J.P.KAUSHIK | 09-08-2019 |
| CHECKED | | |
| APPROVED | B.NATARAJA | 16-08-2019 |
| SCALE | | 1:1 |
| AREA mm ² | | 2200.164 |
| PERIMETER mm. | | 311.287 |
| WEIGHT kg/m | | 5.940 |
| DRAWING No. | SECTION No. | |
| P-19977 | - | |
| S6454 | S6454 | |
| | | |
| | | |

1. ALL DIMENSIONS ARE IN mm.
2. ROUND OFF ALL SHARP CORNERS WITH 0.40 mm.
3. TOLERANCES WILL BE AS PER IS:3965-1981 , UNLESS OTHERWISE SPECIFIED

| | |
|---------------------|--|
| PARTY'S NAME | MOTHERSON SUMI SYSTEMS LTD., BANGALORE |
| PARTY'S DRAWING No. | AS PER DRAWING |
| ALLOY & TEMPER | 6063 T5 |
| DESCRIPTION | H4 COLD PLATE SECTION |