

P-19978

S6455

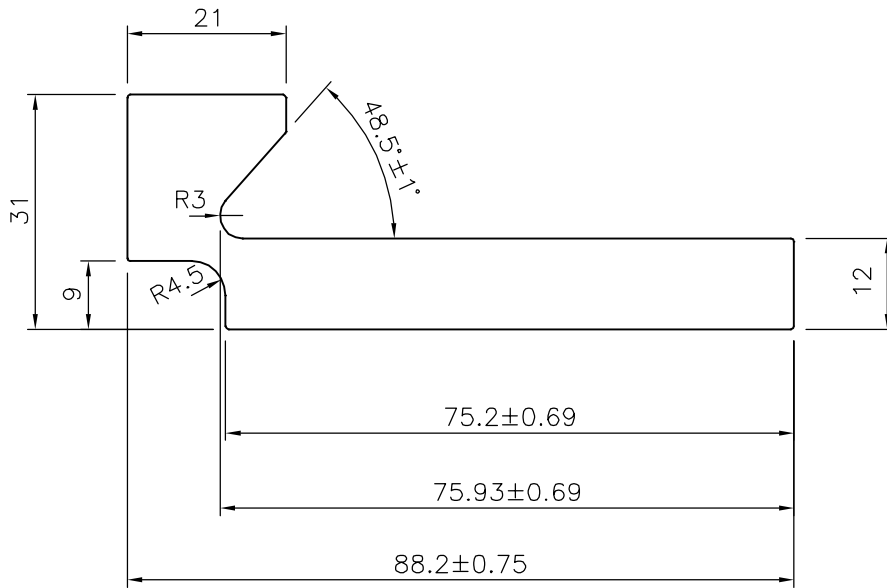

SYMBOL OF QUALITY  
AN ISO 9001 COMPANY

**JINDAL ALUMINIUM LTD.**  
BANGALORE-560073 (INDIA)

	NAME	DATE
DRAWN	J.P.KAUSHIK	09-08-2019
CHECKED		
APPROVED	B.NATARAJA	16-08-2019
SCALE		1:1
AREA mm <sup>2</sup>		1267.469
PERIMETER mm.		246.067
WEIGHT kg/m		3.422
DRAWING No.	SECTION No.	
P-19978	-	
S6455	S6455	

1. ALL DIMENSIONS ARE IN mm.
2. ROUND OFF ALL SHARP CORNERS WITH 0.40 mm.
3. TOLERANCES WILL BE AS PER IS:3965-1981 , UNLESS OTHERWISE SPECIFIED

PARTY'S NAME	MOTHERSON SUMI SYSTEMS LTD., BANGALORE
PARTY'S DRAWING No.	AS PER DRAWING
ALLOY & TEMPER	6063 T5
DESCRIPTION	H3 COLD PLATE SECTION