

P-20017

S6462

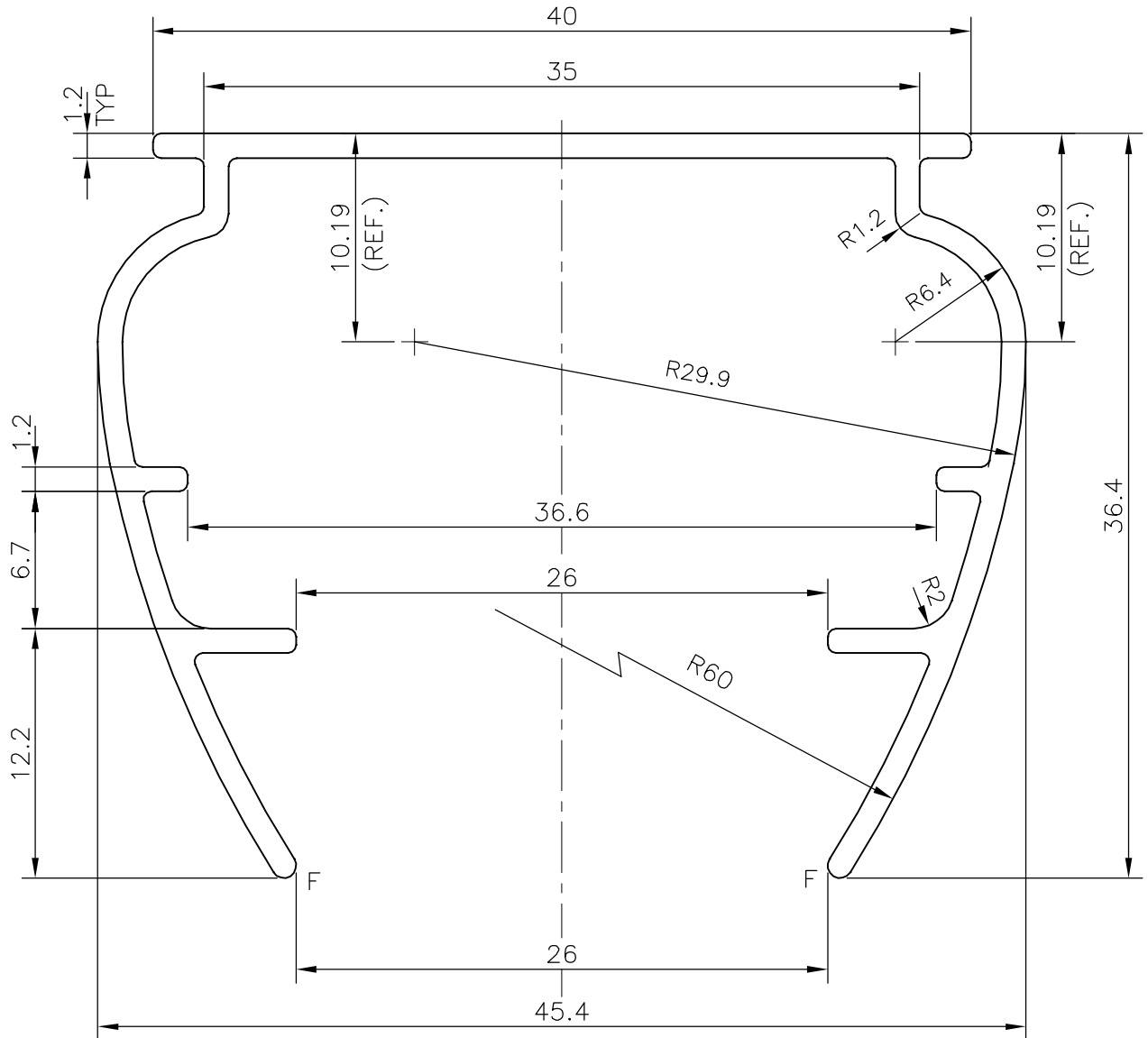
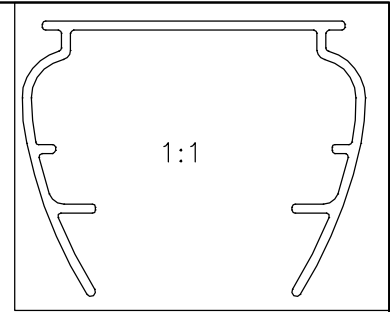

SYMBOL OF QUALITY
AN ISO 9001 COMPANY

JINDAL ALUMINIUM LTD.
BANGALORE-560073 (INDIA)

	NAME	DATE
DRAWN	J.P.KAUSHIK	16-08-2019
CHECKED		
APPROVED	B.NATARAJA	29-08-2019

1. ALL DIMENSIONS ARE IN mm.
2. ROUND OFF ALL SHARP CORNERS WITH 0.40 mm.
3. TOLERANCES WILL BE AS PER IS:3965-1981 , UNLESS OTHERWISE SPECIFIED

SCALE	3:1
AREA mm ²	161.869
PERIMETER mm.	264.762
WEIGHT kg/m	0.437

PARTY'S NAME	N.B.T EXPORTS PVT. LTD., MUMBAI	DRAWING No.	P-20017	SECTION No.	-
PARTY'S DRAWING No.	GM-1555		S6462		S6462
ALLOY & TEMPER	6063 T6				
DESCRIPTION	MISC. SECTION				