

P-19859-1

S6477

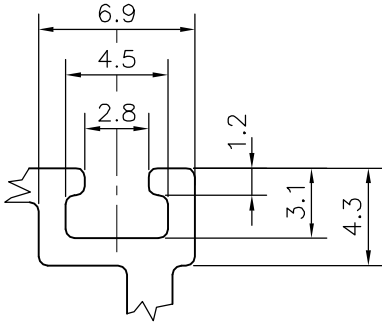

DETAIL OF "A"  
SCALE 3:1

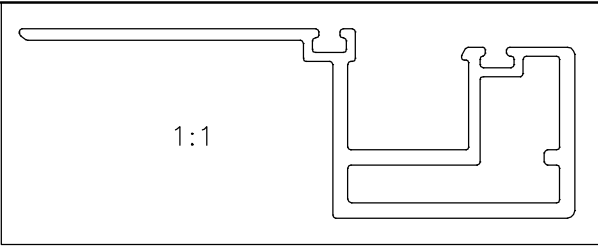
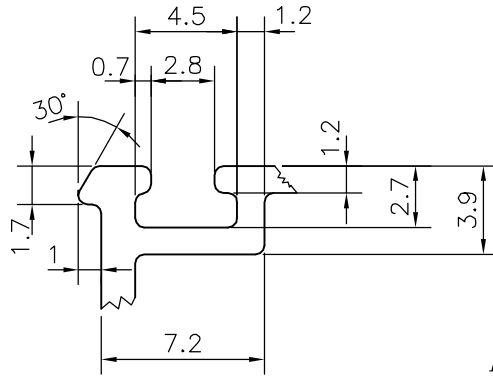

DETAIL OF "B"  
SCALE 3:1

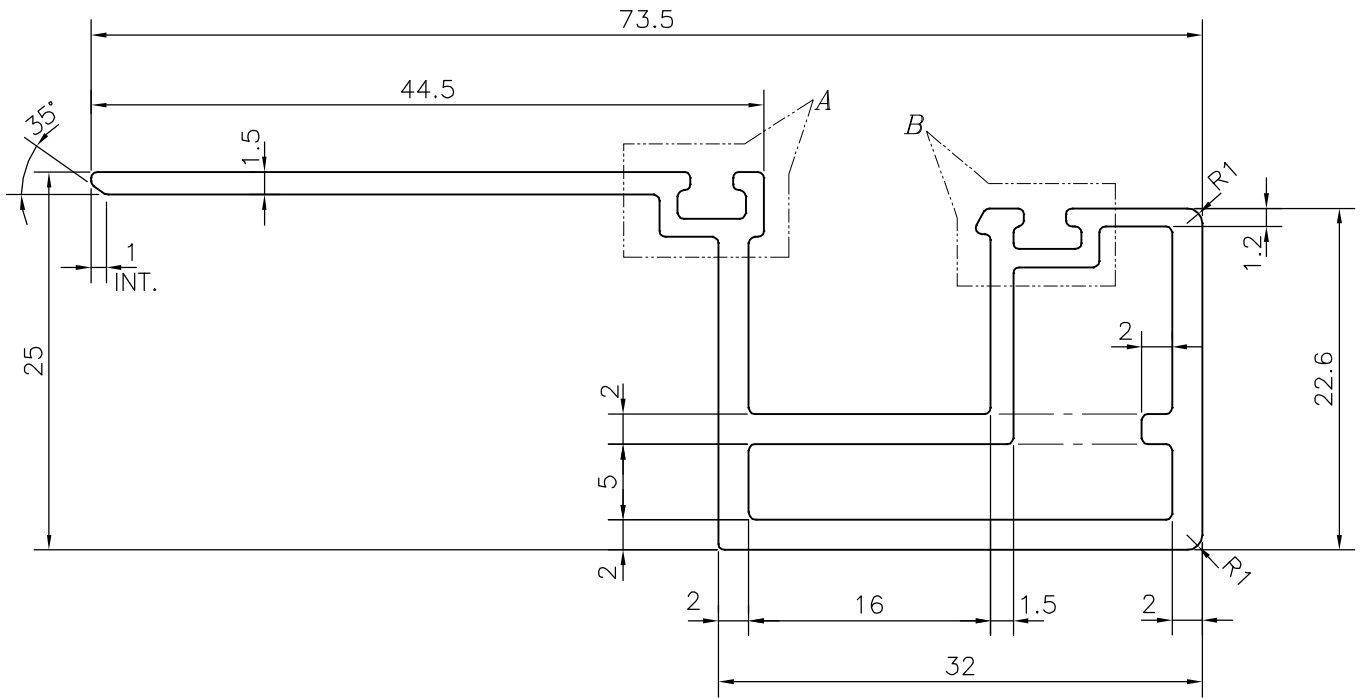

SYMBOL OF QUALITY  
AN ISO 9001 COMPANY

**JINDAL ALUMINIUM LTD.**  
BANGALORE-560073 (INDIA)

	NAME	DATE
DRAWN	J.P.KAUSHIK	22-08-2019
CHECKED		
APPROVED	B.NATARAJA	11-09-2019
SCALE		2:1
AREA mm <sup>2</sup>		294.691
PERIMETER mm.		239.869
WEIGHT kg/m		0.796
DRAWING No.	SECTION No.	
P-19859-1	-	
S6477	S6477	

1. ALL DIMENSIONS ARE IN mm.
2. ROUND OFF ALL SHARP CORNERS WITH 0.40 mm.
3. TOLERANCES WILL BE AS PER IS:6477-1983 , UNLESS OTHERWISE SPECIFIED

PARTY'S NAME	HARDWARE SYNDICATE, BANGALORE
PARTY'S DRAWING No.	AS PER DRAWING
ALLOY & TEMPER	6063 T6
DESCRIPTION	GLASS FRAME FOR 35.52 mm THK. GLASS