

P-20219

S6510

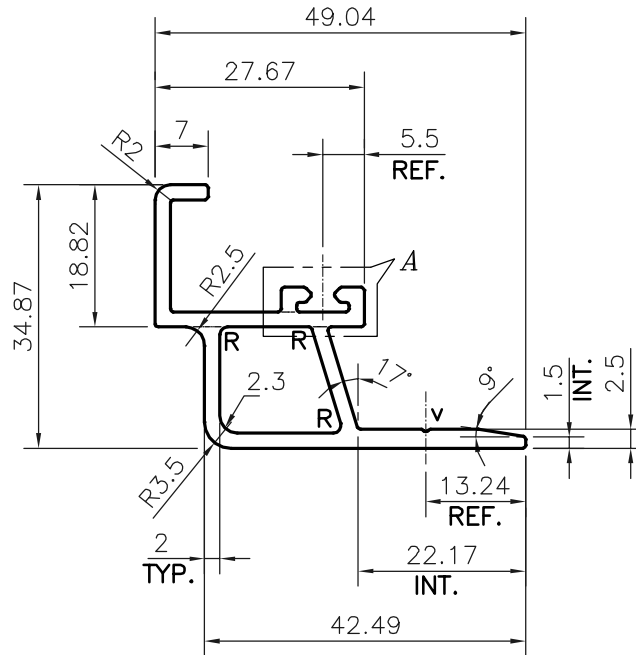
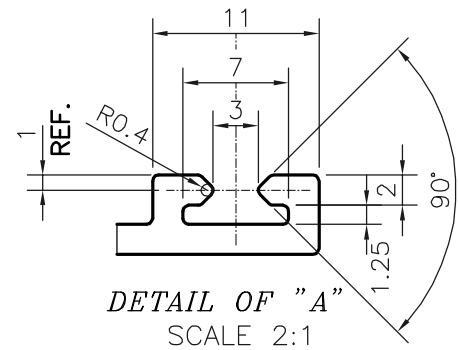

R=R1 (3 PLACES)
V="V" GROOVE 0.3x90° (1 PLACE)

TOLERANCES ON OVERALL DIMENSIONS OF HOLLOW SECTIONS

UPTO 20.0mm - ±0.30	UPTO 80.0mm - ±0.70	UPTO 180.0mm - ±1.27	1. STRAIGHTNESS=1.7mm/M 2. TWIST=1.7mm/M 3. ANGULARITY= ±2° 4. FLATNESS =0.006xWIDTH
UPTO 30.0mm - ±0.38	UPTO 100.0mm - ±0.80	UPTO 200.0mm - ±1.40	
UPTO 40.0mm - ±0.45	UPTO 120.0mm - ±0.90	UPTO 225.0mm - ±1.52	
UPTO 50.0mm - ±0.52	UPTO 140.0mm - ±1.00		
UPTO 60.0mm - ±0.60	UPTO 160.0mm - ±1.14		



SYMBOL OF QUALITY
AN ISO 9001 COMPANY

JINDAL ALUMINIUM LTD.
BANGALORE-560073 (INDIA)

	NAME	DATE
DRAWN	DARPAN	05-10-2019
CHECKED		
APPROVED	B.NATARAJA	18-10-2019
SCALE		1:1
AREA mm ²		268.444
PERIMETER mm.		195.985
WEIGHT kg/m		0.725
DRAWING No.		SECTION No.
P-20219		-
S6510		S6510

1. ALL DIMENSIONS ARE IN mm.
2. ROUND OFF ALL SHARP CORNERS WITH 0.40 mm.
3. TOLERANCES WILL BE AS PER IS:6477-1983, UNLESS OTHERWISE SPECIFIED

PARTY'S NAME	NEW ERA INDUSTRIES, NEW DELHI
PARTY'S DRAWING No.	NEI-24-03
ALLOY & TEMPER	6063 T6
DESCRIPTION	ALU. CLAMP (BOTTOM)