

P-20368-1

S6562

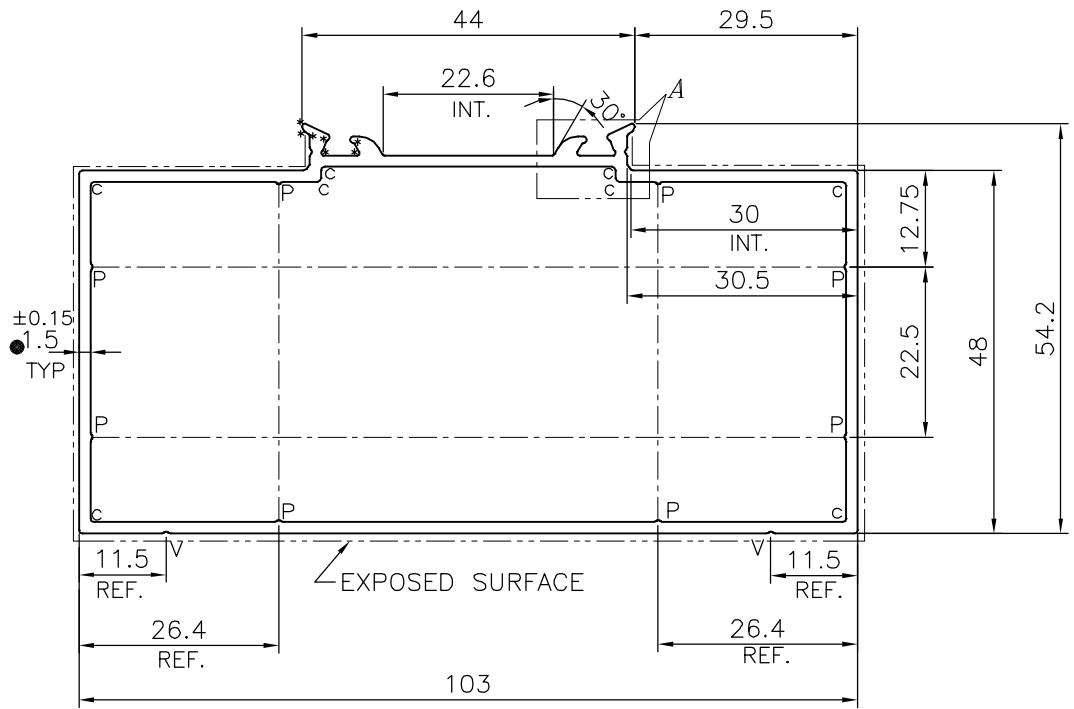
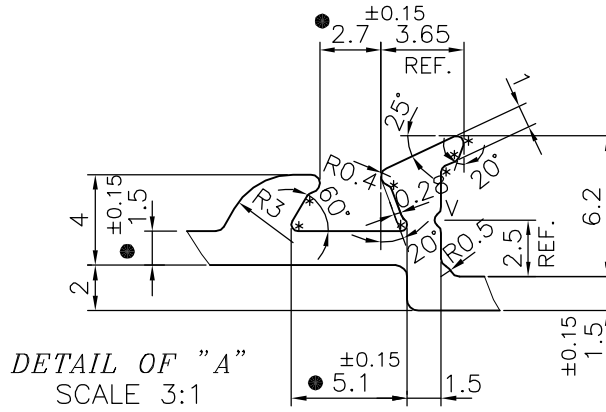

TOLERANCE #	
0.5-<10	±0.15
10-<25	±0.20
25-<50	±0.35
50-<100	±0.80

1. STRAIGHTNESS=1.7mm/M
2. TWIST=1.7mm/M
3. ANGULARITY= ±1°
4. FLATNESS =0.006xWIDTH

- = MARKED CRITICAL DIMENSION
- c = 0.5 RADIUS (8 PLACES)
- P = PIP 0.3x90° (8 PLACES)
- * = 0.3 RADIUS (14 PLACES)
- V = V GROOVE 0.3x90° (2 PLACES)



SYMBOL OF QUALITY
AN ISO 9001 COMPANY

JINDAL ALUMINIUM LTD.
BANGALORE-560073 (INDIA)

	NAME	DATE
DRAWN	J.P.KAUSHIK	08-11-2019
CHECKED		
APPROVED	B.NATARAJA	22-11-2019
SCALE		1:1
AREA mm ²		481.155
PERIMETER mm.		335.104
WEIGHT kg/m		1.299
DRAWING No.	SECTION No.	
P-20368-1	-	
S6562	S6562	

1. ALL DIMENSIONS ARE IN mm.
2. ROUND OFF ALL SHARP CORNERS WITH 0.40 mm.
3. TOLERANCES WILL BE AS PER IS:6477-1983, UNLESS OTHERWISE SPECIFIED

PARTY'S NAME	VIVANT SOLUTION PVT. LTD., CHENNAI
PARTY'S DRAWING No.	VS252-481-SR
ALLOY & TEMPER	6063 T6
DESCRIPTION	AIR GRILL SECTION