

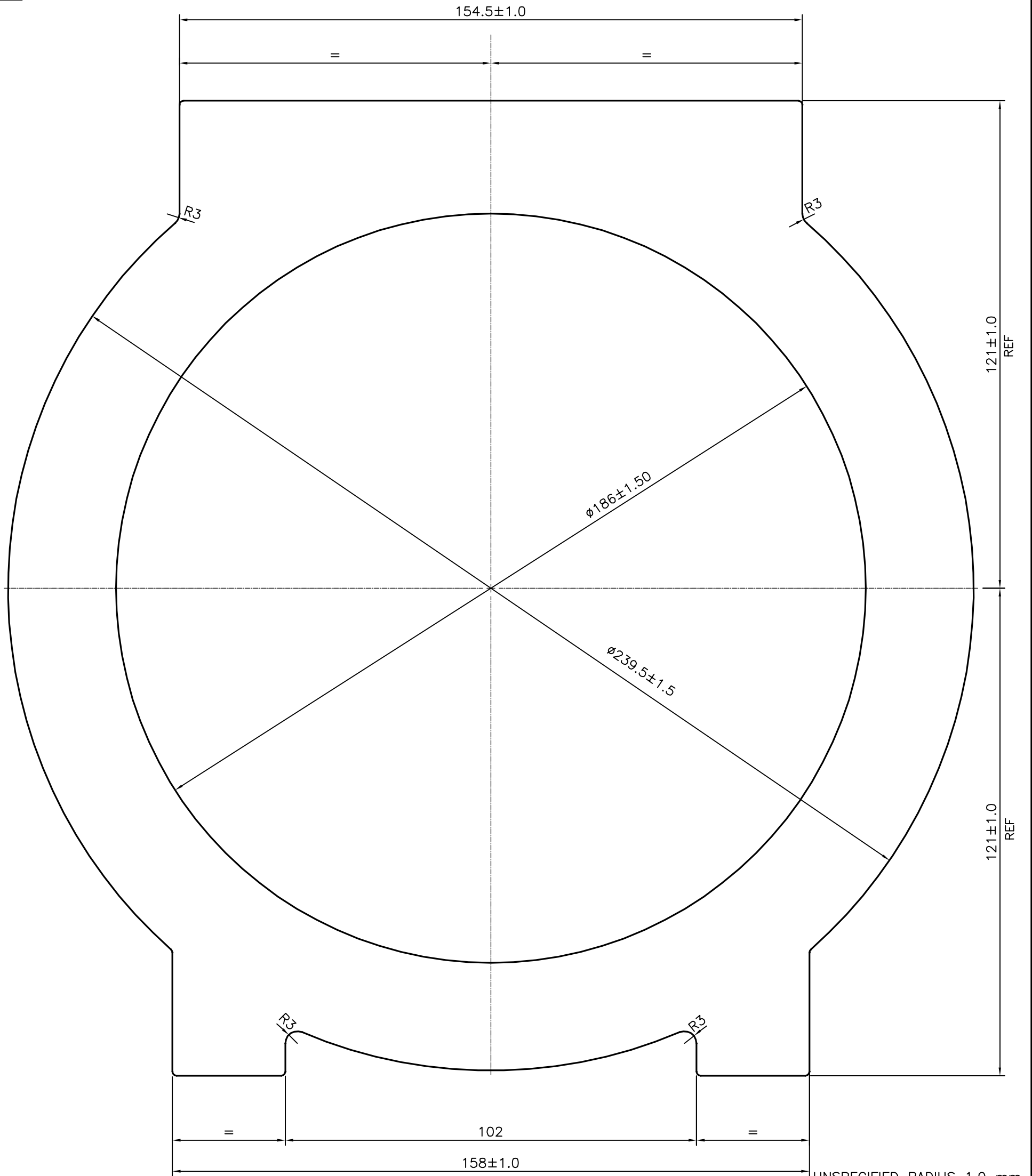

P-20436-2

S6592



UNSPECIFIED RADIUS 1.0 mm

 SYMBOL OF QUALITY AN ISO 9001 COMPANY	<b>JINDAL ALUMINIUM LTD.</b> BANGALORE-560073 (INDIA)	NAME	DATE
		DRAWN	J.P.KAUSHIK 29-11-2019
1. ALL DIMENSIONS ARE IN mm. 2. ROUND OFF ALL SHARP CORNERS WITH 0.40 mm. 3. TOLERANCES WILL BE AS PER IS:6477-1983 UNLESS OTHERWISE SPECIFIED		CHECKED	
		APPROVED	B.NATARAJA 06-12-2019
PARTY'S NAME ACE MULTI AXIS SYSTEMS LTD., BANGALORE		SCALE	1:1
		AREA mm <sup>2</sup>	20629.438
PARTY'S DRAWING No. 5817315DDW & REQUIREMENT		PERIMETER mm.	864.523
		WEIGHT kg/m	55.699
ALLOY & TEMPER 6061 T6		DRAWING No.	SECTION No.
		P-20436-2	-
DESCRIPTION GE VENUSR CENTER SECTION		S6592	S6592