

P-20514

S6625

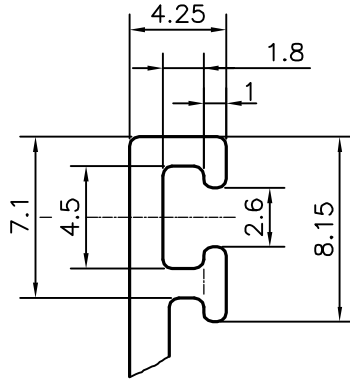

DETAIL OF "A"  
SCALE 3:1

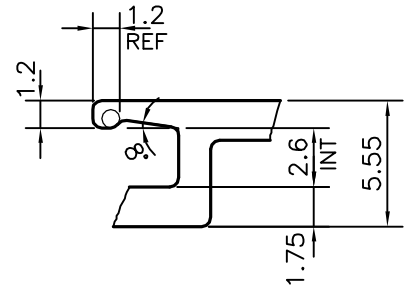

DETAIL OF "B"  
SCALE 3:1

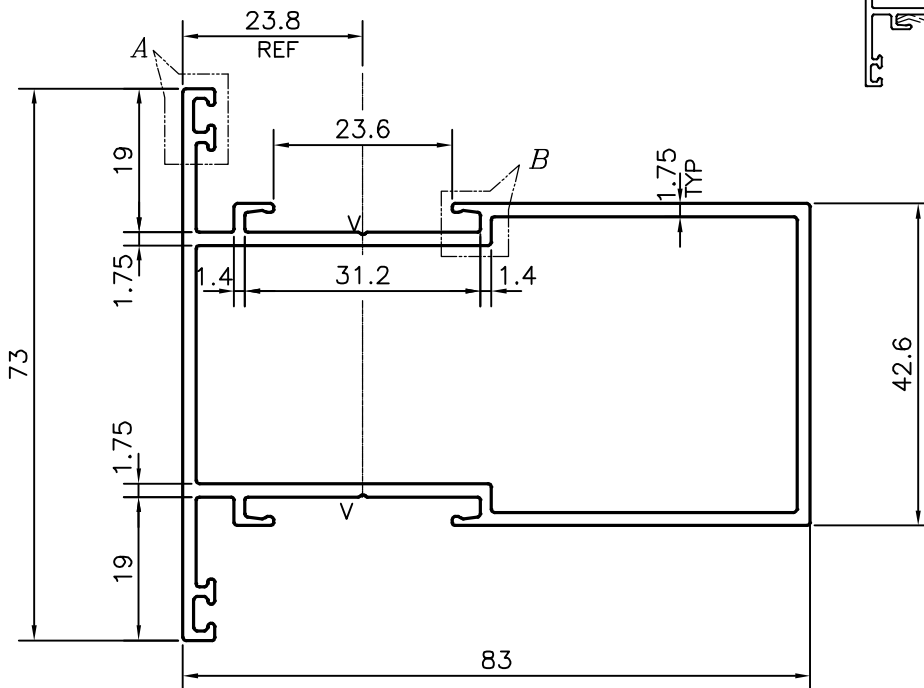
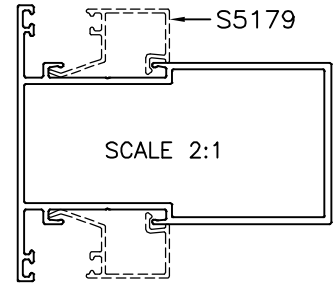

V = V GROOVE 0.3x90°(2 PLACES)

TOLERANCES ON OVERALL DIMENSIONS OF HOLLOW SECTIONS

UPTO 20.0mm - ±0.30	UPTO 80.0mm - ±0.70	UPTO 180.0mm - ±1.27	1. STRAIGHTNESS=1.7mm/M 2. TWIST=1.7mm/M 3. ANGULARITY= ±2° 4. FLATNESS =0.006xWIDTH
UPTO 30.0mm - ±0.38	UPTO 100.0mm - ±0.80	UPTO 200.0mm - ±1.40	
UPTO 40.0mm - ±0.45	UPTO 120.0mm - ±0.90	UPTO 225.0mm - ±1.52	
UPTO 50.0mm - ±0.52	UPTO 140.0mm - ±1.00		
UPTO 60.0mm - ±0.60	UPTO 160.0mm - ±1.14		



SYMBOL OF QUALITY  
AN ISO 9001 COMPANY

**JINDAL ALUMINIUM LTD.**  
BANGALORE-560073 (INDIA)

	NAME	DATE
DRAWN	J.P.KAUSHIK	18-12-2019
CHECKED		
APPROVED	B.NATARAJA	26-12-2019

1. ALL DIMENSIONS ARE IN mm.
2. ROUND OFF ALL SHARP CORNERS WITH 0.40 mm.
3. TOLERANCES WILL BE AS PER IS:6477-1983 , UNLESS OTHERWISE SPECIFIED

SCALE	1:1
AREA mm <sup>2</sup>	533.916
PERIMETER mm.	397.957
WEIGHT kg/m	1.442

PARTY'S NAME	DEO LEELA FACADE SYSTEMS LLP, PUNE
PARTY'S DRAWING No.	DLFS-009
ALLOY & TEMPER	6063 T6
DESCRIPTION	WINDOW SECTION-MULLION

DRAWING No.	SECTION No.
P-20514	-
S6625	S6625