

P-20571

S6681

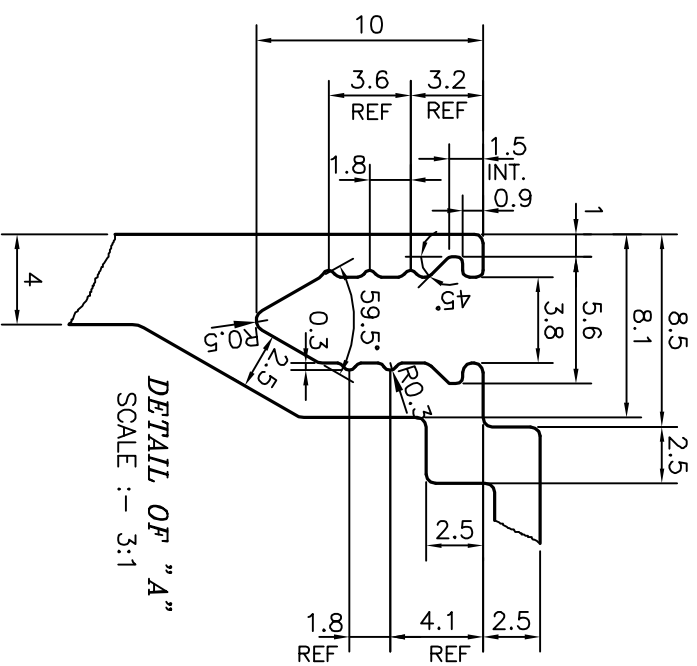
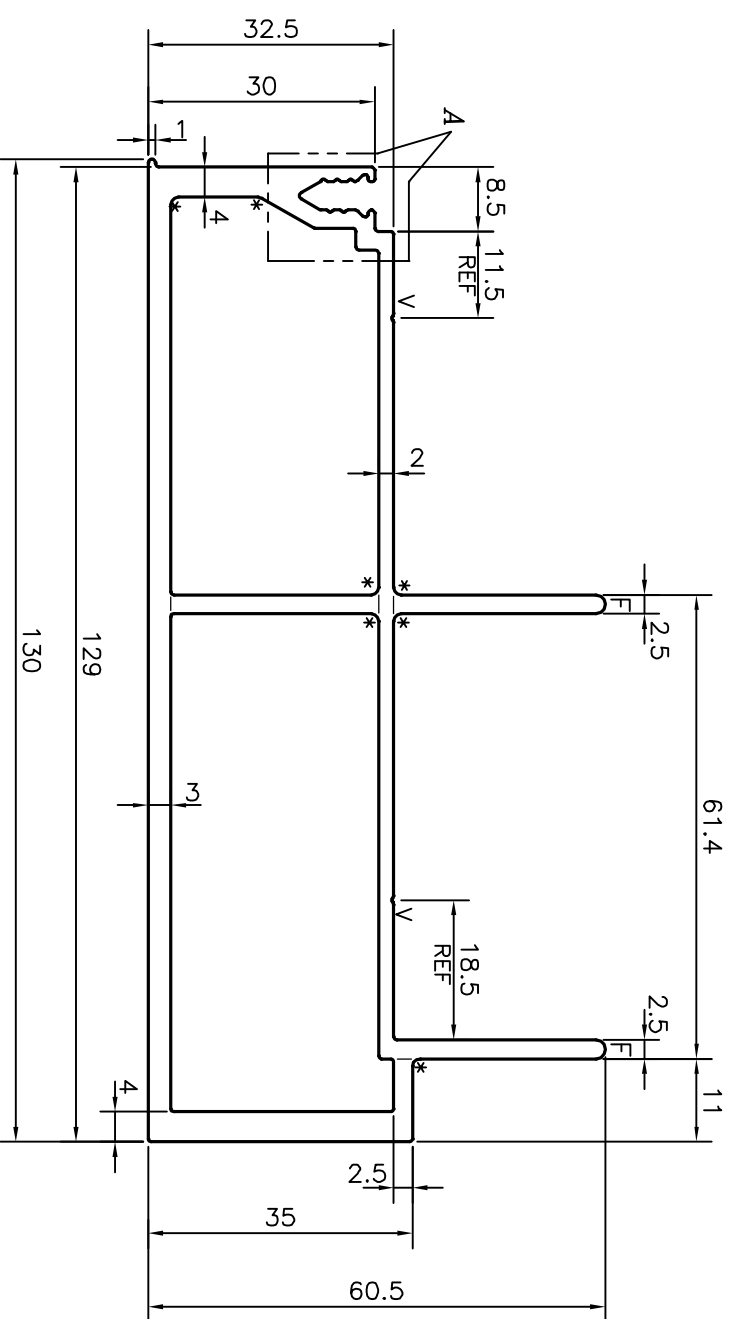
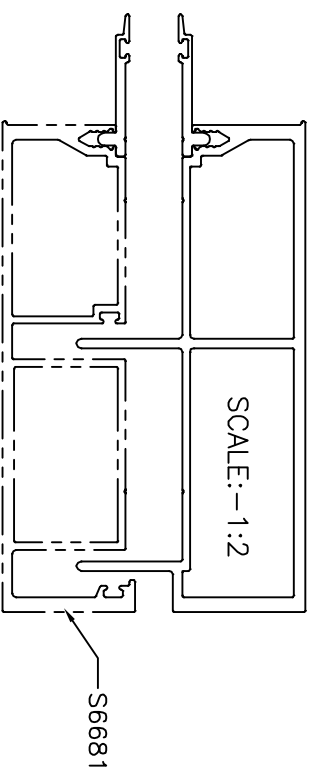

V= V GROOVE 0.3x90° (2 PLACES)
 * = 1.0 RADIUS (7 PLACES)
 F = FULL RADIUS (2 PLACES)

TOLERANCES ON OVERALL DIMENSIONS OF HOLLOW SECTIONS

UPTO 20.0mm - ±0.30	UPTO 80.0mm - ±0.70	UPTO 180.0mm - ±1.27
UPTO 30.0mm - ±0.38	UPTO 100.0mm - ±0.80	UPTO 200.0mm - ±1.40
UPTO 40.0mm - ±0.45	UPTO 120.0mm - ±0.90	UPTO 225.0mm - ±1.52
UPTO 50.0mm - ±0.52	UPTO 140.0mm - ±1.00	
UPTO 60.0mm - ±0.60	UPTO 160.0mm - ±1.14	



JINDAL ALUMINIUM LTD.
 BANGALORE-560073 (INDIA)

1. ALL DIMENSIONS ARE IN mm.
2. ROUND OFF ALL SHARP CORNERS WITH 0.40 mm.
3. TOLERANCES WILL BE AS PER IS:6477-1983 UNLESS OTHERWISE SPECIFIED

PARTY'S NAME	GLAZIUM FACADES PVT. LTD., PUNE	SCALE	1:1
PARTY'S DRAWING No.	AS PER DRAWING	AREA mm ²	1088.857
ALLOY & TEMPER	6063 T6	PERIMETER mm.	452.651
DESCRIPTION	CURTAIN WALL SECTION	WEIGHT kg/m	2.940
		DRAWING No.	P-20571
		SECTION No.	-
			S6681
			S6681

NAME	DATE
J.P. KAUSHIK	02-01-2020

CHECKED	
APPROVED	B.NATARAJA

SCALE	1:1
-------	-----

AREA mm ²	1088.857
PERIMETER mm.	452.651
WEIGHT kg/m	2.940

DRAWING No.	P-20571
SECTION No.	-

	S6681
	S6681