

P-20573

S6682

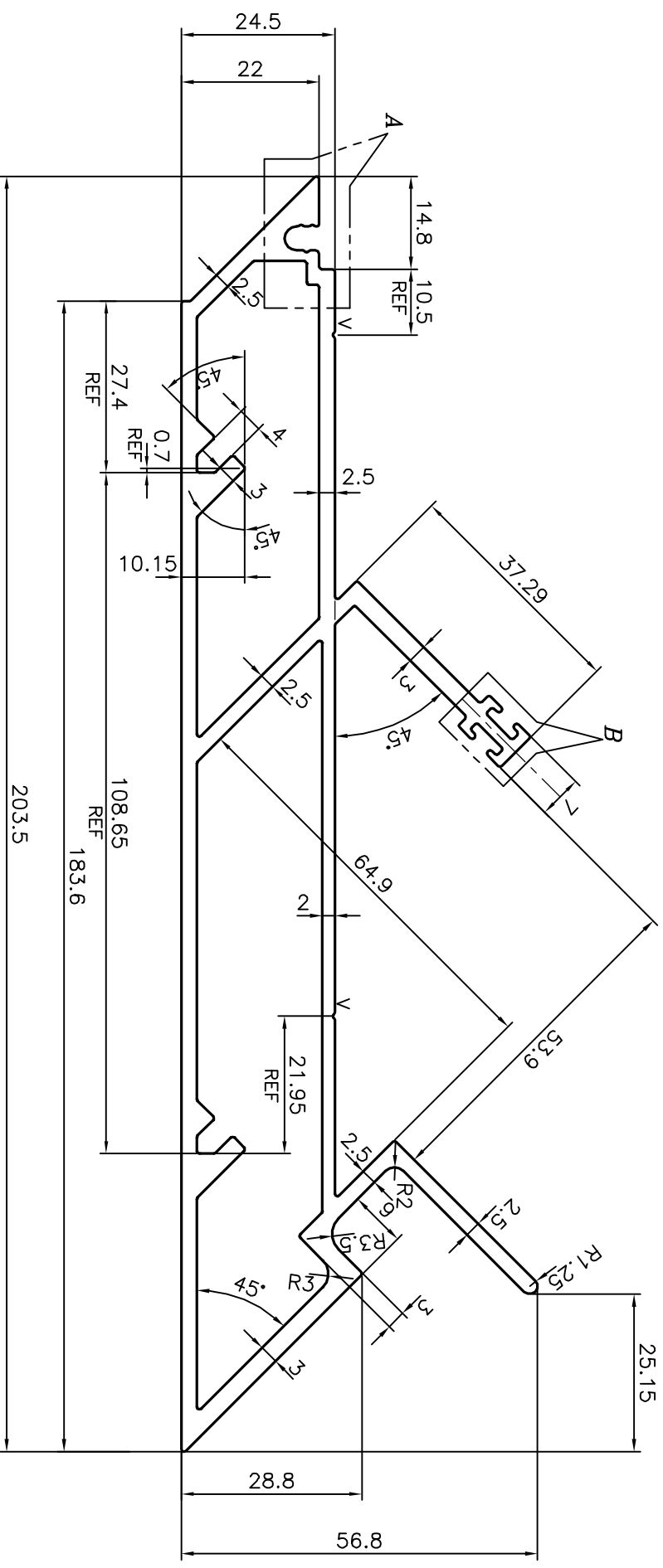
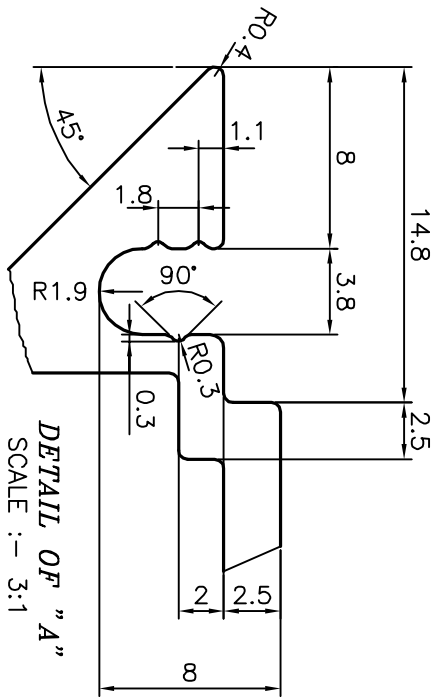
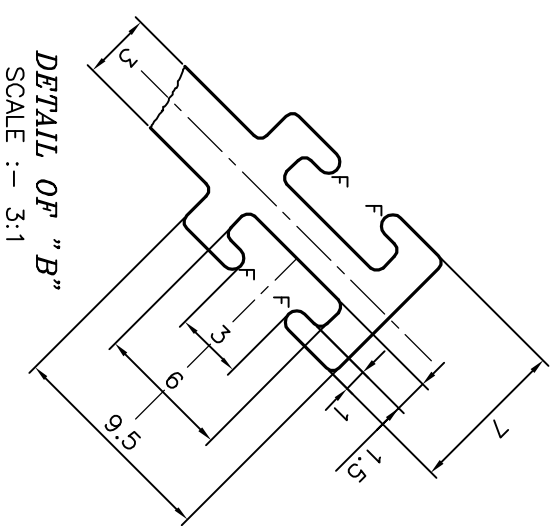

V= V GROOVE 0.3x90° (2 PLACES)
 F= FULL RADIUS (4 PLACES)

TOLERANCES ON OVERALL DIMENSIONS OF HOLLOW SECTIONS			
UPTO 20.0mm - ±0.30	UPTO 80.0mm - ±0.70	UPTO 180.0mm - ±1.27	1. STRAIGHTNESS=1.7mm/M 2. TWIST=1.7mm/M 3. ANGULARITY= ±2° 4. FLATNESS =0.006xWIDTH
UPTO 30.0mm - ±0.38	UPTO 100.0mm - ±0.80	UPTO 200.0mm - ±1.40	
UPTO 40.0mm - ±0.45	UPTO 120.0mm - ±0.90	UPTO 225.0mm - ±1.52	
UPTO 50.0mm - ±0.52	UPTO 140.0mm - ±1.00		
UPTO 60.0mm - ±0.60	UPTO 160.0mm - ±1.14		

<p>SYMBOL OF QUALITY AN ISO 9001 COMPANY</p>	<p>JINDAL ALUMINIUM LTD.</p> <p>BANGALORE-560073 (INDIA)</p>	
	<p>1. ALL DIMENSIONS ARE IN mm. 2. ROUND OFF ALL SHARP CORNERS WITH 0.40 mm. 3. TOLERANCES WILL BE AS PER IS:6477-1983 UNLESS OTHERWISE SPECIFIED</p>	<p>SCALE</p> <p>1:1</p>

PARTY'S NAME	GLAZIUM FACADES PVT. LTD., PUNE	DRAWN	J.P. KAUSHIK	DATE	03-01-2020
PARTY'S DRAWING No.	AS PER DRAWING	CHECKED		APPROVED	B.NATARAJA
ALLOY & TEMPER	6063 T6	SCALE	1:1	AREA	1443.684
DESCRIPTION	CURTAIN WALL SECTION	PERIMETER	634.554	WEIGHT	3.898
		DRAWING No.	P-20573	SECTION No.	-
			S6682		S6682

