

P-20576

S6719

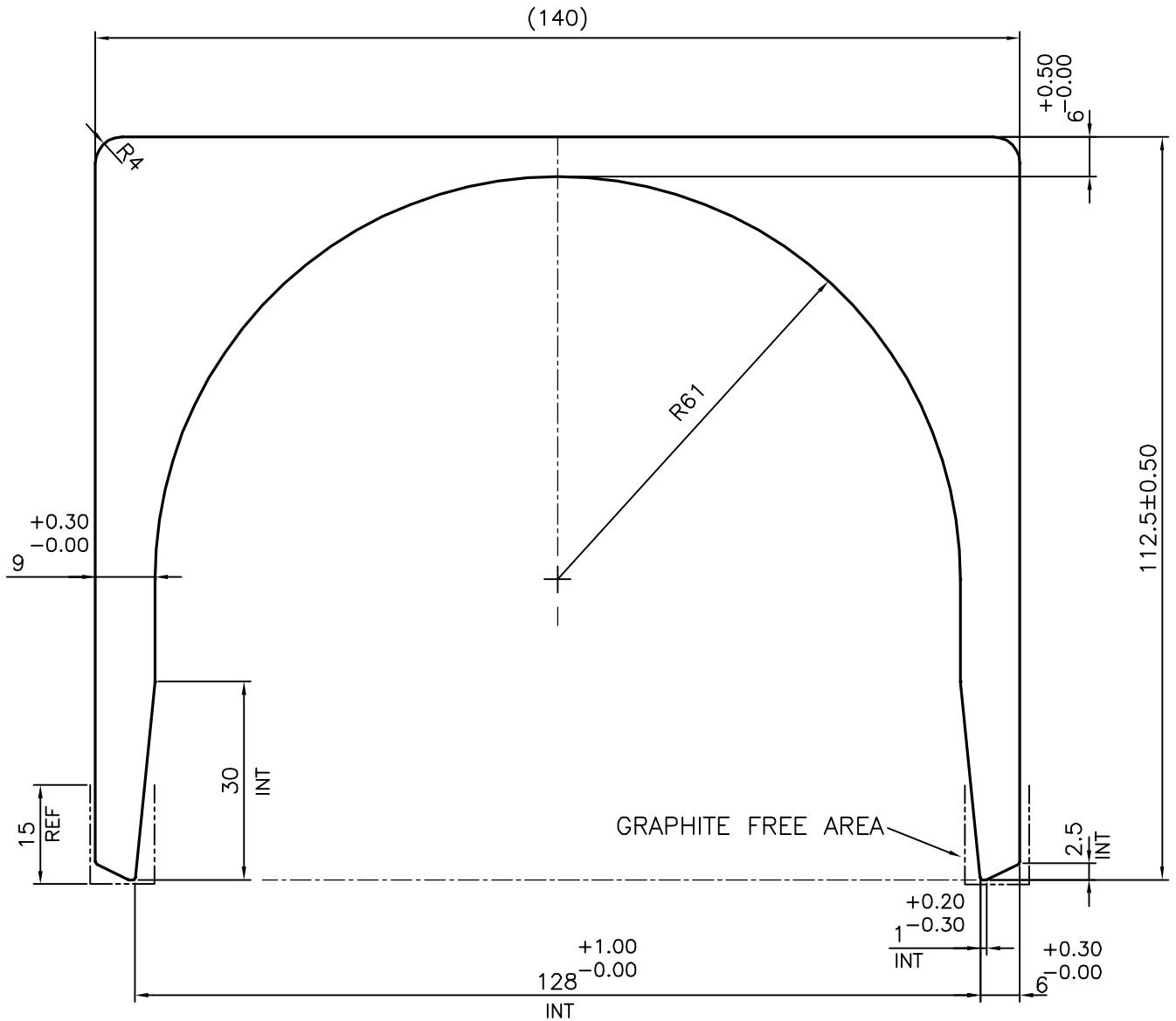

- |                                    |   |
|------------------------------------|---|
| 1 TENSILE STRENGTH:-215MPa Minimum | 7 ALL DETAIL AS PER DELIVERY SPECIFICATION No:-415001-eng |
| 2 YIELD POINT:-160MPa Minimum      | 8 SURFACE ROUGHNESS VALUE AS Rz 25 um                     |
| 3 FRACTURE ELONGATION:-12% Minimum | 9 ORDER LENGTH 5 Mtr ± 5mm                                |
| 4 STRAIGHTNESS=0.5mm/M             |   |
| 5. FLATNESS =1.0mm/M               |   |
| 6 TWIST=0.5mm/M                    |   |



SYMBOL OF QUALITY  
AN ISO 9001 COMPANY

**JINDAL ALUMINIUM LTD.**  
BANGALORE-560073 (INDIA)

	NAME	DATE
DRAWN	J.P.KAUSHIK	04-01-2020
CHECKED		
APPROVED	B.NATARAJA	18-02-2020
SCALE		1:1
AREA mm <sup>2</sup>		4244.623
PERIMETER mm.		652.302
WEIGHT kg/m		11.460
DRAWING No.	SECTION No.	
P-20576	-	
S6719	S6719	

- ALL DIMENSIONS ARE IN mm.
- ROUND OFF ALL SHARP CORNERS WITH 0.40 mm.
- TOLERANCES WILL BE AS PER IS:3965-1981, UNLESS OTHERWISE SPECIFIED

PARTY'S NAME	AKG INDIA PVT. LTD., COIMBATORE
PARTY'S DRAWING No.	8420.013.0000
ALLOY & TEMPER	6060 T66
DESCRIPTION	CHANNEL-MISC.