

P-20699

S6729

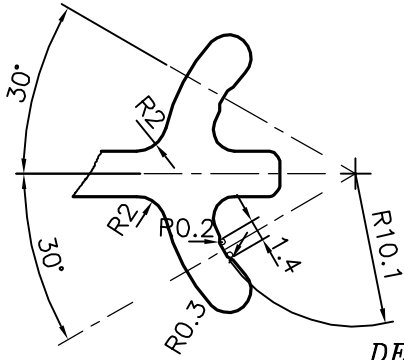

DETAIL OF "A"
SCALE 2:1

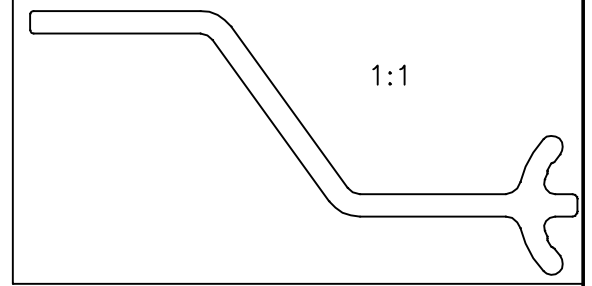

1:1

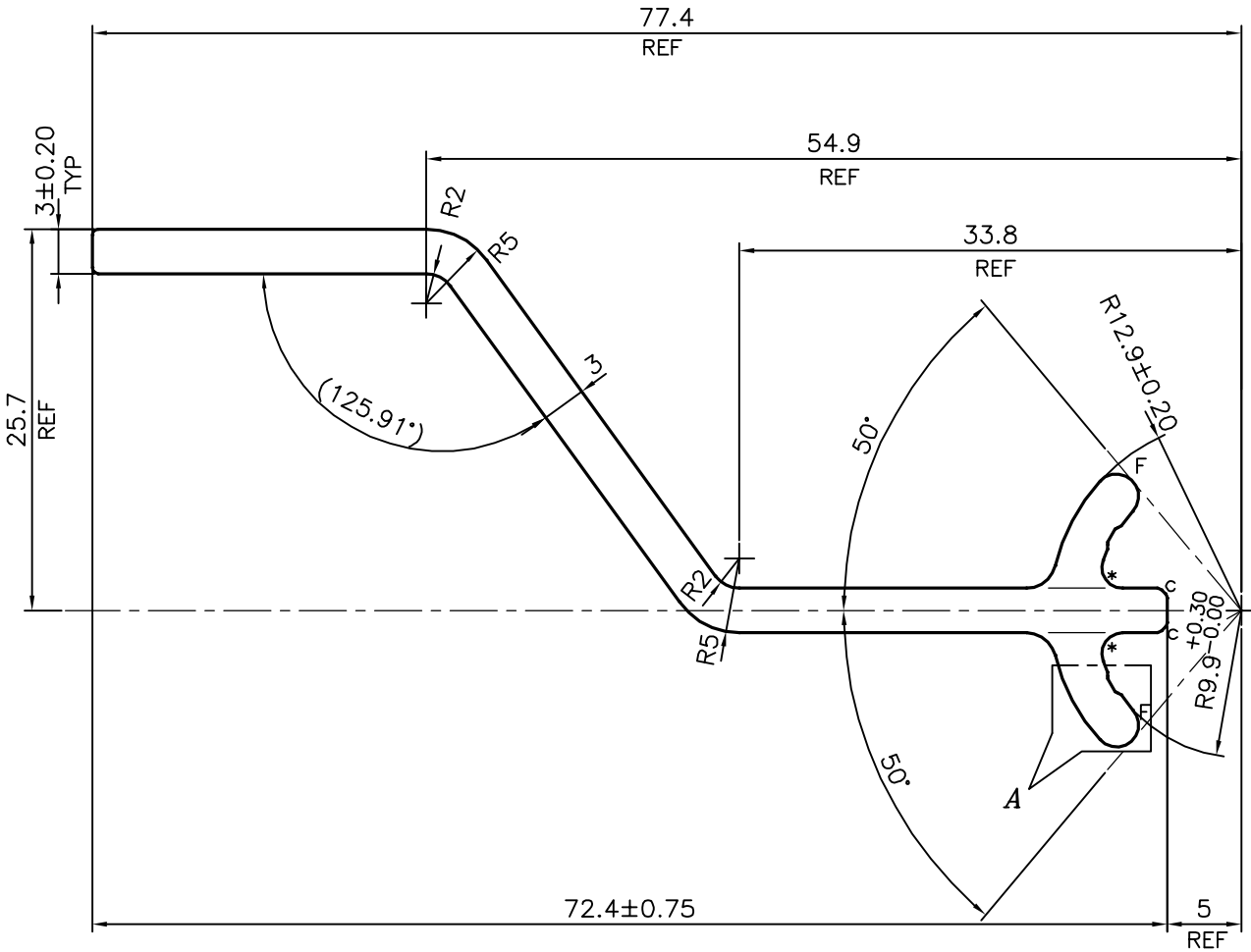

c = CHAMFER 0.5x45°(2 PLACES)
 F = FULL RADIUS (2 PLACES)
 * = 1.4 RADIUS (2 PLACES)



SYMBOL OF QUALITY
AN ISO 9001 COMPANY

JINDAL ALUMINIUM LTD.
 BANGALORE-560073 (INDIA)

	NAME	DATE
DRAWN	J.P.KAUSHIK	07-02-2020
CHECKED		
APPROVED	B.NATARAJA	21-02-2020

1. ALL DIMENSIONS ARE IN mm.
2. ROUND OFF ALL SHARP CORNERS WITH 0.40 mm.
3. TOLERANCES WILL BE AS PER,IS:3965-1981 UNLESS OTHERWISE SPECIFIED

SCALE	2:1
AREA mm ²	303.104
PERIMETER mm.	201.654
WEIGHT kg/m	0.818

PARTY'S NAME	INFLUENCE 360 AUTOCOMPONENTS PVT. LTD., PUNE
PARTY'S DRAWING No.	AS PER DRAWING
ALLOY & TEMPER	6061 T6
DESCRIPTION	LH ATOC BRACKET SECTION

DRAWING No.	SECTION No.
P-20699	-
S6729	S6729