

P-20707

S6736

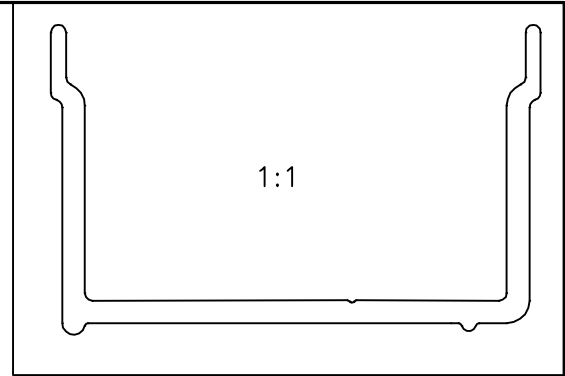

1:1

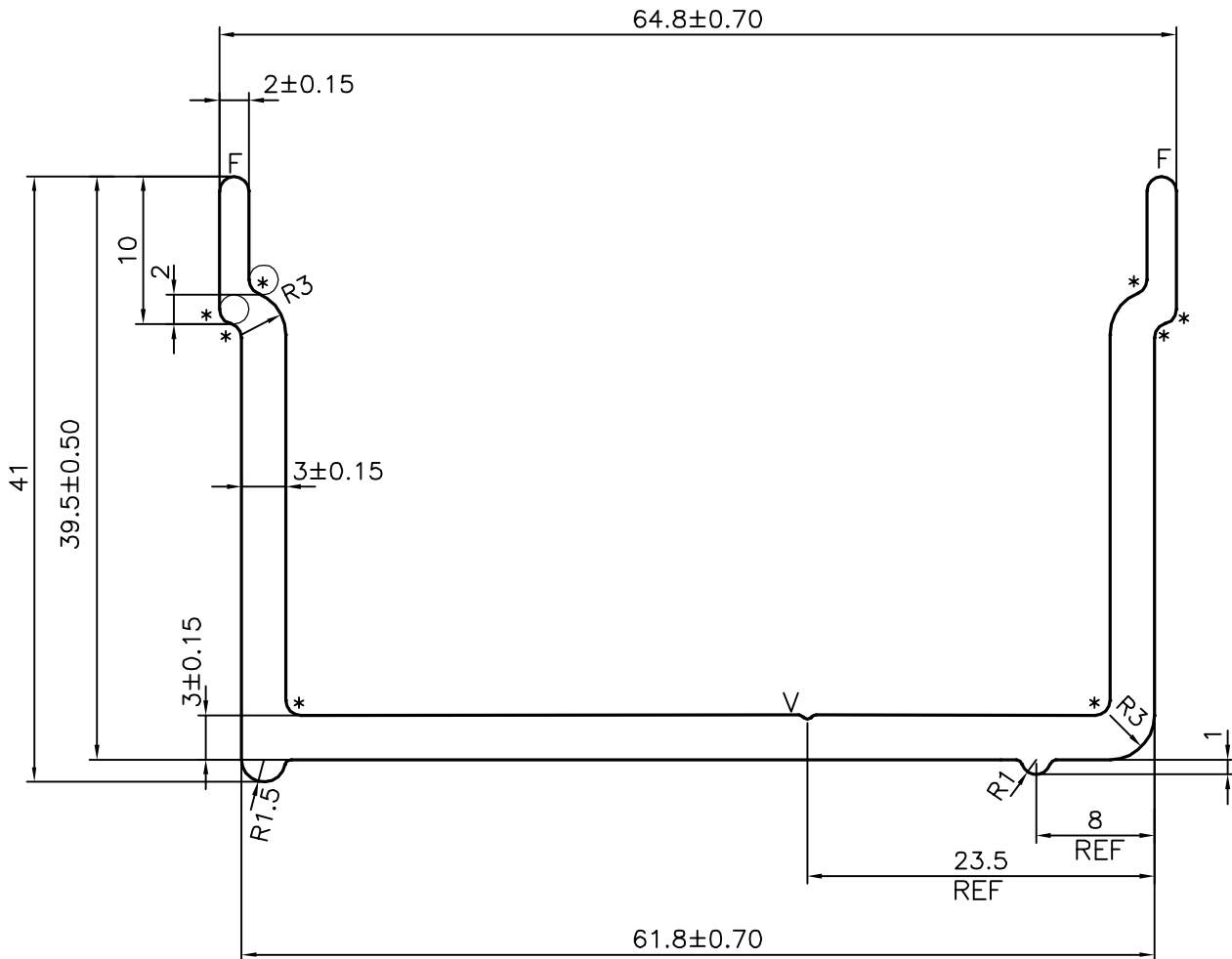

* = 1.0 RADIUS (8 PLACES)
 F = FULL RADIUS (2 PLACES)
 V = V GROOVE 0.3x90° (1 PLACE)



SYMBOL OF QUALITY
 AN ISO 9001 COMPANY

JINDAL ALUMINIUM LTD.
 BANGALORE-560073 (INDIA)

	NAME	DATE
DRAWN	J.P.KAUSHIK	10-02-2020
CHECKED		
APPROVED	B.NATARAJA	21-02-2020
SCALE		2:1
AREA mm ²		395.506
PERIMETER mm.		275.884
WEIGHT kg/m		1.068
DRAWING No.	SECTION No.	
P-20707	-	
S6736	S6736	

1. ALL DIMENSIONS ARE IN mm.
2. ROUND OFF ALL SHARP CORNERS WITH 0.40 mm.
3. TOLERANCES WILL BE AS PER,IS:3965-1981 UNLESS OTHERWISE SPECIFIED

PARTY'S NAME	FACADE CLAD TECH PVT. LTD., BANGALORE
PARTY'S DRAWING No.	23-09-19
ALLOY & TEMPER	6063 T6
DESCRIPTION	CURTAIN WALL SECTION