

P-20692

S6774

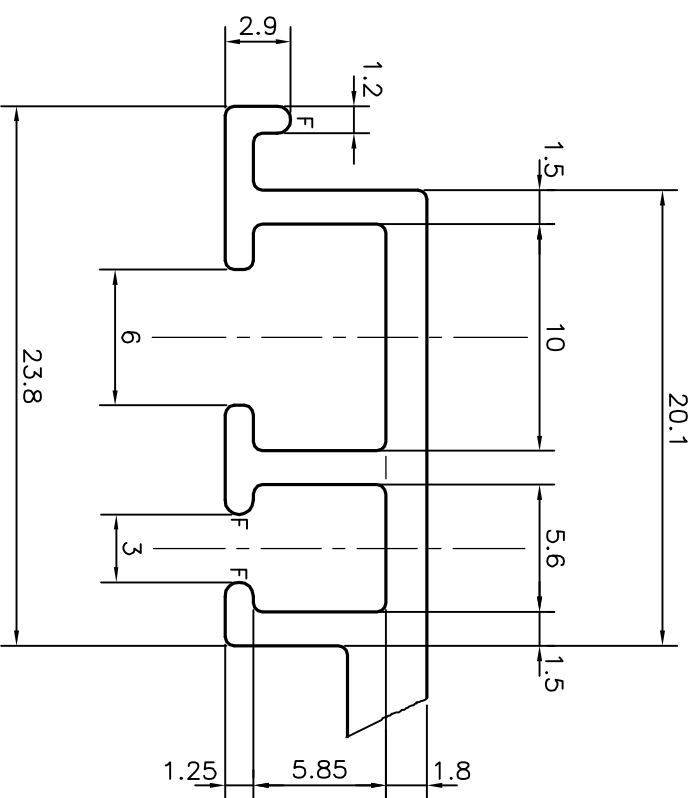
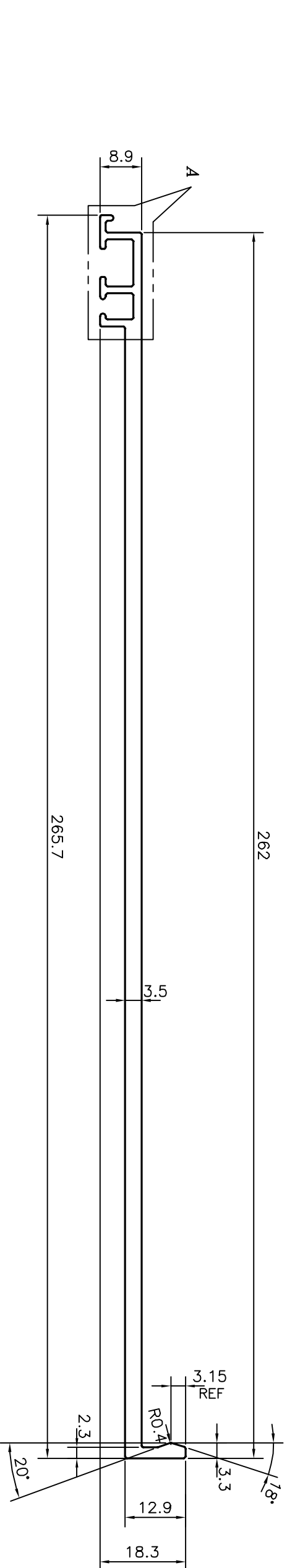

DETAIL OF "A"
SCALE 3:1

F = FULL RADIUS (3 PLACES)

TOLERANCES ON OVERALL WIDTHS & WIDTHS ACROSS FLATS OF BARS, & REGULAR SECTIONS			
UPTO 6.40mm - ±0.20	UPTO 32.0mm - ±0.38	UPTO 120.0mm - ±0.85	UPTO 320.00mm - ±1.70
UPTO 10.0mm - ±0.23	UPTO 50.0mm - ±0.46	UPTO 160.0mm - ±1.02	
UPTO 12.0mm - ±0.25	UPTO 60.0mm - ±0.53	UPTO 200.0mm - ±1.14	
UPTO 16.0mm - ±0.28	UPTO 80.0mm - ±0.69	UPTO 250.0mm - ±1.40	
UPTO 25.0mm - ±0.30	UPTO 100.0mm - ±0.75	UPTO 300.0mm - ±1.65	

 <p>SYMBOL OF QUALITY AN ISO 9001 COMPANY</p>		<p>JINDAL ALUMINIUM LTD. BANGALORE-560073 (INDIA)</p>	
<p>1. ALL DIMENSIONS ARE IN mm. 2. ROUND OFF ALL SHARP CORNERS WITH 0.40 mm. 3. TOLERANCES WILL BE AS PER IS:3965-1981 UNLESS OTHERWISE SPECIFIED</p>			
PARTY'S NAME	GLAZIUM FACADES PVT. LTD., PUNE	DRAWN	J.P. KAUSHIK
PARTY'S DRAWING No.	AS PER DRAWING	CHECKED	
ALLOY & TEMPER	6063 T6	APPROVED	B. NATARAJA
DESCRIPTION	WINDOW OUT SIDE SECTION	SCALE	1:1
		AREA	953.899
		PERIMETER	607.956
		WEIGHT kg/m	2.576
		DRAWING No.	P-20692
		SECTION No.	-
			S6774
			S6774