

P-20846

S6792

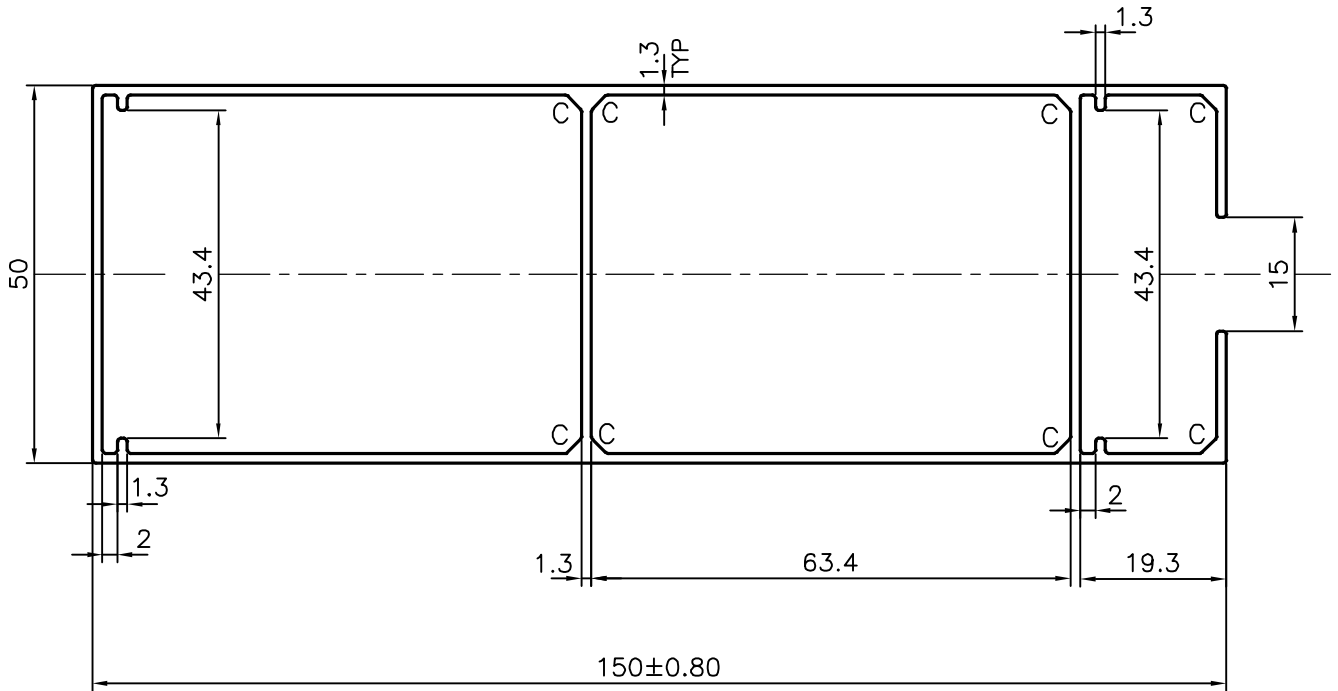

C = CHAMFER 2x45° (8 PLACES)

TOLERANCES ON OVERALL WIDTHS & WIDTHS ACROSS FLATS OF BARS, & REGULAR SECTIONS

UPTO 6.40mm - ± 0.20	UPTO 32.0mm - ± 0.38	UPTO 120.0mm - ± 0.85	UPTO 320.00mm - ± 1.70
UPTO 10.0mm - ± 0.23	UPTO 50.0mm - ± 0.46	UPTO 160.0mm - ± 1.02	
UPTO 12.0mm - ± 0.25	UPTO 60.0mm - ± 0.53	UPTO 200.0mm - ± 1.14	
UPTO 16.0mm - ± 0.28	UPTO 80.0mm - ± 0.69	UPTO 250.0mm - ± 1.40	
UPTO 25.0mm - ± 0.30	UPTO 100.0mm - ± 0.75	UPTO 300.0mm - ± 1.65	



SYMBOL OF QUALITY
AN ISO 9001 COMPANY

JINDAL ALUMINIUM LTD.
BANGALORE-560073 (INDIA)

	NAME	DATE
DRAWN	J.P.KAUSHIK	02-03-2020
CHECKED		
APPROVED	B.NATARAJA	17-03-2020

- ALL DIMENSIONS ARE IN mm.
- ROUND OFF ALL SHARP CORNERS WITH 0.40 mm.
- TOLERANCES WILL BE AS PER IS:6477-1983 UNLESS OTHERWISE SPECIFIED

SCALE	1:1
AREA mm ²	643.294
PERIMETER mm.	505.898
WEIGHT kg/m	1.737

PARTY'S NAME DURLUM INDIA PVT. LTD., MANESAR

PARTY'S DRAWING No. AS PER DRAWING

ALLOY & TEMPER 6063 T6

DESCRIPTION MISC. SECTION

DRAWING No.	SECTION No.
P-20846	
S6792	S6792