

P-JAL-B-333

X101371

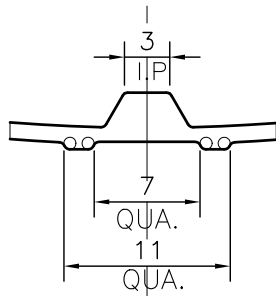

DETAIL "A"
SCALE:- 2:1

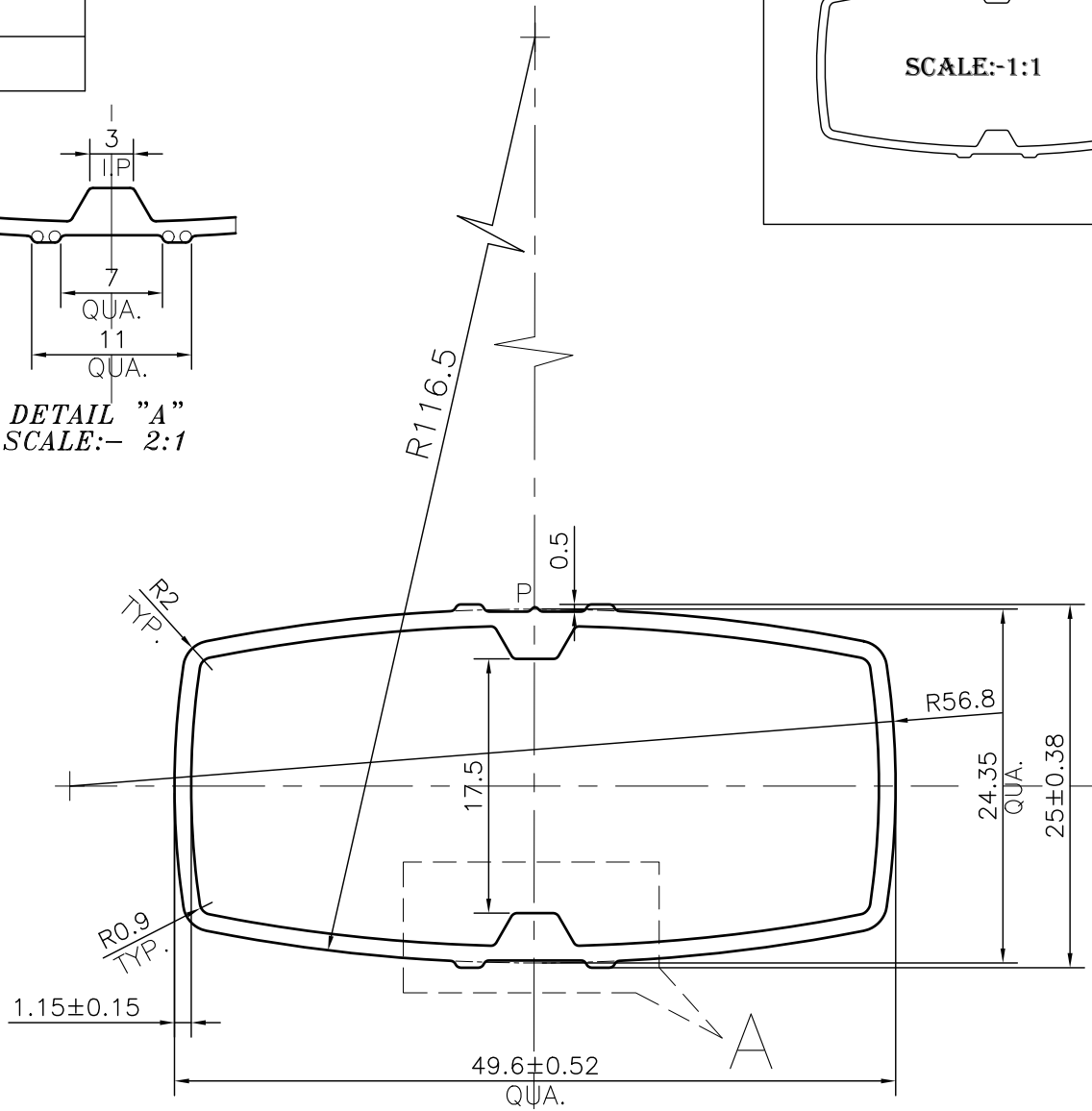

NOTE:-

P= 0.3x90° PIP (1 PLACE)

CONTROLLED COPY

TOLERANCES ON OVERALL DIMENSIONS OF HOLLOW SECTIONS

UPTO 20.0mm - ±0.30	UPTO 80.0mm - ±0.70	UPTO 180.0mm - ±1.27	1. STRAIGHTNESS=1.7mm/M 2. TWIST=1.7mm/M 3. ANGULARITY= ±2° 4. FLATNESS =0.006xWIDTH
UPTO 30.0mm - ±0.38	UPTO 100.0mm - ±0.80	UPTO 200.0mm - ±1.40	
UPTO 40.0mm - ±0.45	UPTO 120.0mm - ±0.90	UPTO 225.0mm - ±1.52	
UPTO 50.0mm - ±0.52	UPTO 140.0mm - ±1.00		
UPTO 60.0mm - ±0.60	UPTO 160.0mm - ±1.14		



SYMBOL OF QUALITY
AN ISO 9001 COMPANY

JINDAL ALUMINIUM LTD.
BHIWADI-301019 (INDIA)

	NAME	DATE
DRAWN	ASHUTOSH	14-09-2023
CHECKED	PARVESH	23-09-2023
APPROVED	J.N. RAI	23-09-2023

- ALL DIMENSIONS ARE IN mm.
- ROUND OFF ALL SHARP CORNERS WITH 0.40 mm.
- TOLERANCES WILL BE AS PER BS:EN-755-9 , UNLESS OTHERWISE SPECIFIED

SCALE	2:1
AREA mm ²	170.684
PERIMETER mm.	135.864
WEIGHT kg/m	0.461
DRAWING No.	SECTION No.

PARTY'S NAME	ATCO ALUMINIUM SYSTEM, DELHI	
PARTY'S DRAWING No.	AS PER MAIL-14.08.2023	
ALLOY & TEMPER	HE9 WP	PRODUCT CODE:-049
		HSN CODE:- 76042100
DESCRIPTION	VENETIAN BLINDS	

P-JAL-B-333	
X101371	X101371