

P-JAL-B-562-1

X102423

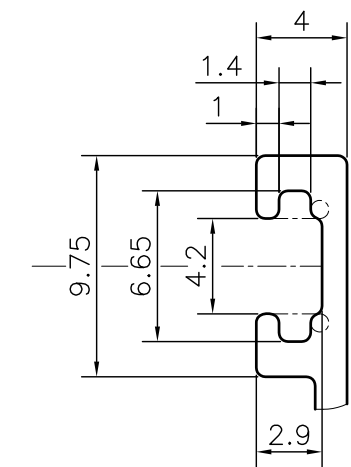
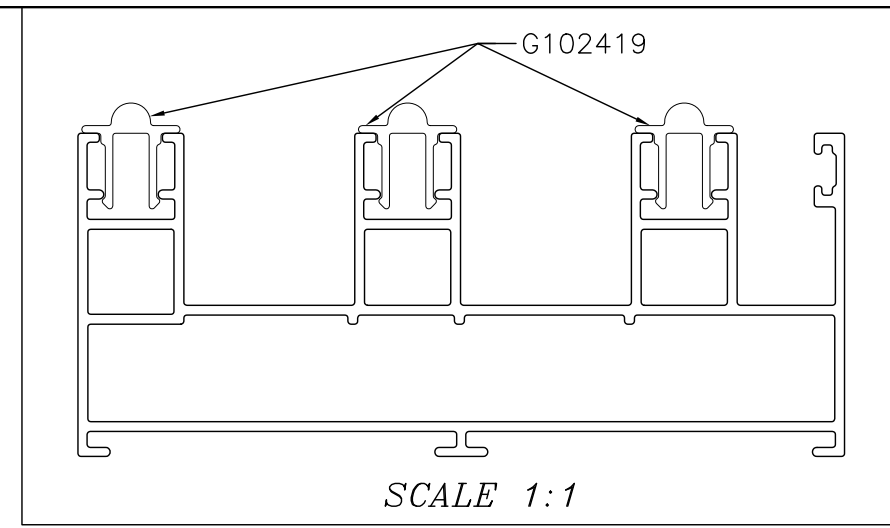
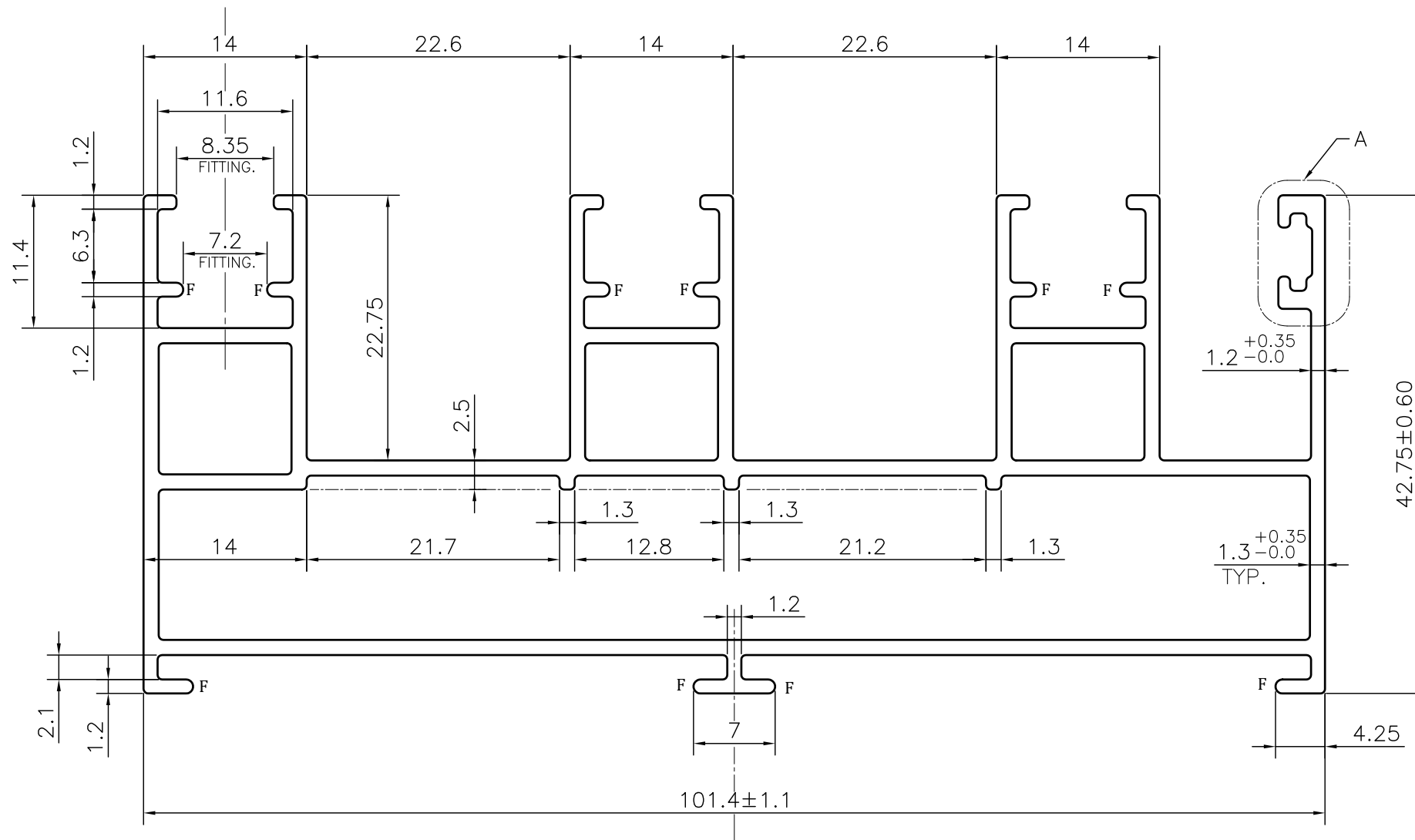

☞ WEIGHT WILL COME ALWAYS ON HIGHER SIDE ONLY

TOLERANCE CHART CD = CIRCUMSCRIBING CIRCLE

| DIMENSION | CD ≤ 100 | 100 < CD ≤ 200 | 200 < CD ≤ 300 | 300 < CD ≤ 500 |
|-------------|----------|----------------|----------------|----------------|
| UPTO 10mm | ±0.25 | ±0.30 | ±0.35 | ±0.40 |
| 10.0 - 25.0 | ±0.30 | ±0.40 | ±0.50 | ±0.60 |
| 25.0 - 50.0 | ±0.50 | ±0.60 | ±0.80 | ±0.90 |
| 50.0 - 100 | ±0.70 | ±0.90 | ±1.10 | ±1.30 |
| 100 - 150 | - | ±1.10 | ±1.30 | ±1.50 |
| 150 - 200 | - | ±1.3 | ±1.50 | ±1.80 |
| 200 - 300 | - | - | ±1.70 | ±2.10 |
| 300 - 450 | - | - | - | ±2.80 |

Q01903

CONTROLLED COPY

NOTE:-

F= FULL RADIUS (10 PLACES)

1. STRAIGHTNESS= 1.7mm/M
2. TWIST= 1.7mm/M
3. ANGULARITY= ±2°
4. FLATNESS= 0.007xWIDTH

| | | | | | |
|---|--|--|----------------------|-------------|------------|
|  SYMBOL OF QUALITY AN ISO 9001 COMPANY | JINDAL ALUMINIUM LTD. BHIWADI-301019 (INDIA) | | NAME | DATE | |
| | | | DRAWN | ASHUTOSH | 06-06-2024 |
| 1. ALL DIMENSIONS ARE IN mm. 2. ROUND OFF ALL SHARP CORNERS WITH 0.40 mm. 3. TOLERANCES WILL BE AS PER BS:EN-755-9 , UNLESS OTHERWISE SPECIFIED | | | CHECKED | PARVESH | 02-07-2024 |
| | | | APPROVED | N.K.HOLEY | 03-07-2024 |
| PARTY'S NAME WINDOOR TECH, GURUGRAM | | | SCALE | 2:1 | |
| | | | AREA mm ² | 613.824 | |
| PARTY'S DRAWING No. AS PER CAD DRAWING | | | PERIMETER mm. | 574.647 | |
| | | | WEIGHT kg/m | 1.657 | |
| ALLOY & TEMPER 6063 T6 | | | DRAWING No. | SECTION No. | |
| | | | P-JAL-B-562-1 | 7000002604 | |
| DESCRIPTION WINDOW SECTION-3 TRACK SHUTTER-25 MM SERIES | | | X102423 | X102423 | |
| | | | PRODUCT CODE:-048 | | |
| | | | HSN CODE:- 76042100 | | |