

P-JAL-B-580-1

X102448

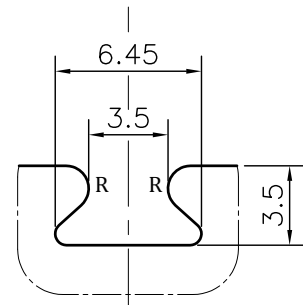

DETAIL A  
SCALE 3:1

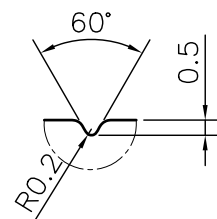

DETAIL V  
SCALE 4:1

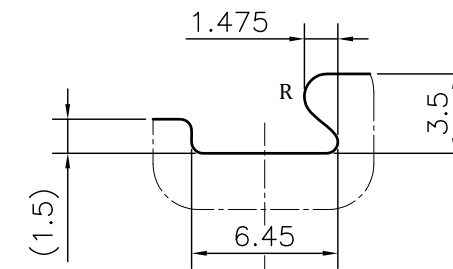
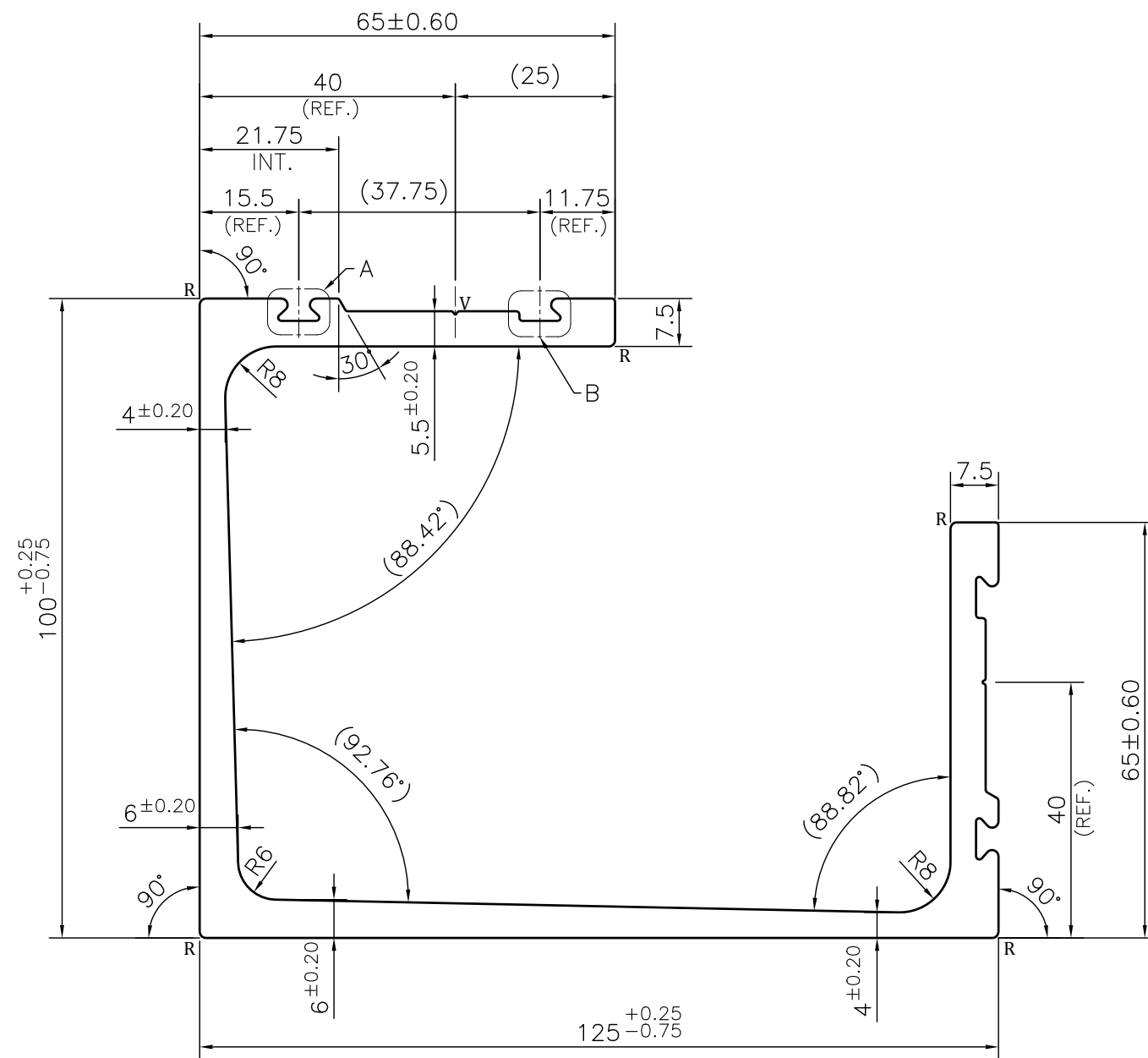

DETAIL B  
SCALE 3:1

NOTE:-

- ☞ ROUND OFF ALL SHARP CORNERS WITH 0.50 mm.
- ☞ FE:- NOT MORE THAN 0.4%, MG:- 0.8 TO 1.2%
- ☞ HARDNESS :- 56HRB
- ☞ UTS :- 280 TO 300 MIN MPA

NOTE:-

- R= 1.0 RADIUS (11 PLACES)**
- V= 0.5x60° V-GROOVE (2 PLACES)**

1. STRAIGHTNESS= 1.0mm/M
2. TWIST= 1.0mm/M
3. ANGULARITY= ±1°
4. FLATNESS= ±0.5mm

Q01982

CONTROLLED COPY

 SYMBOL OF QUALITY AN ISO 9001 COMPANY	<b>JINDAL ALUMINIUM LTD.</b> BHIWADI-301019 (INDIA)	NAME	DATE
		DRAWN	ASHUTOSH 11-06-2024
1. ALL DIMENSIONS ARE IN mm. 2. ROUND OFF ALL SHARP CORNERS WITH 0.50 mm. 3. TOLERANCES WILL BE AS PER EN 12020-2, UNLESS OTHERWISE SPECIFIED		CHECKED	PARVESH 04-07-2024
		APPROVED	N.K.HOLEY 04-07-2024
PARTY'S NAME		KNEST MANUFACTURERS LLP, PUNE	
PARTY'S DRAWING No.		AS PER DRAWING	
ALLOY & TEMPER		6061 T6	
DESCRIPTION		FORM WORK SECTION- 125 IC	
		SCALE	1:1
		AREA mm <sup>2</sup>	1846.64
		PERIMETER mm.	712.61
		WEIGHT kg/m	4.986
		DRAWING No.	SECTION No.
		P-JAL-B-580-1	7000002616
		X102448	X102448
		PRODUCT CODE:-029	
		HSN CODE:- 76042990	