

P-JAL-B-581-1

X102449

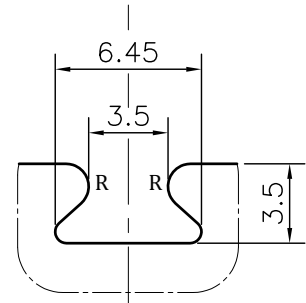

DETAIL A  
SCALE 3:1

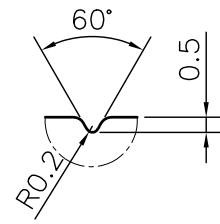

DETAIL V  
SCALE 4:1

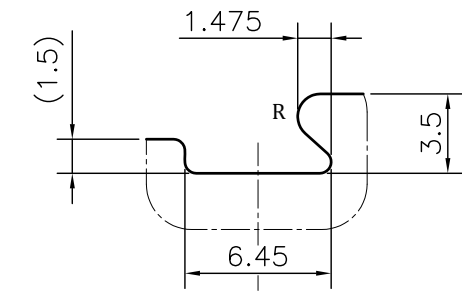
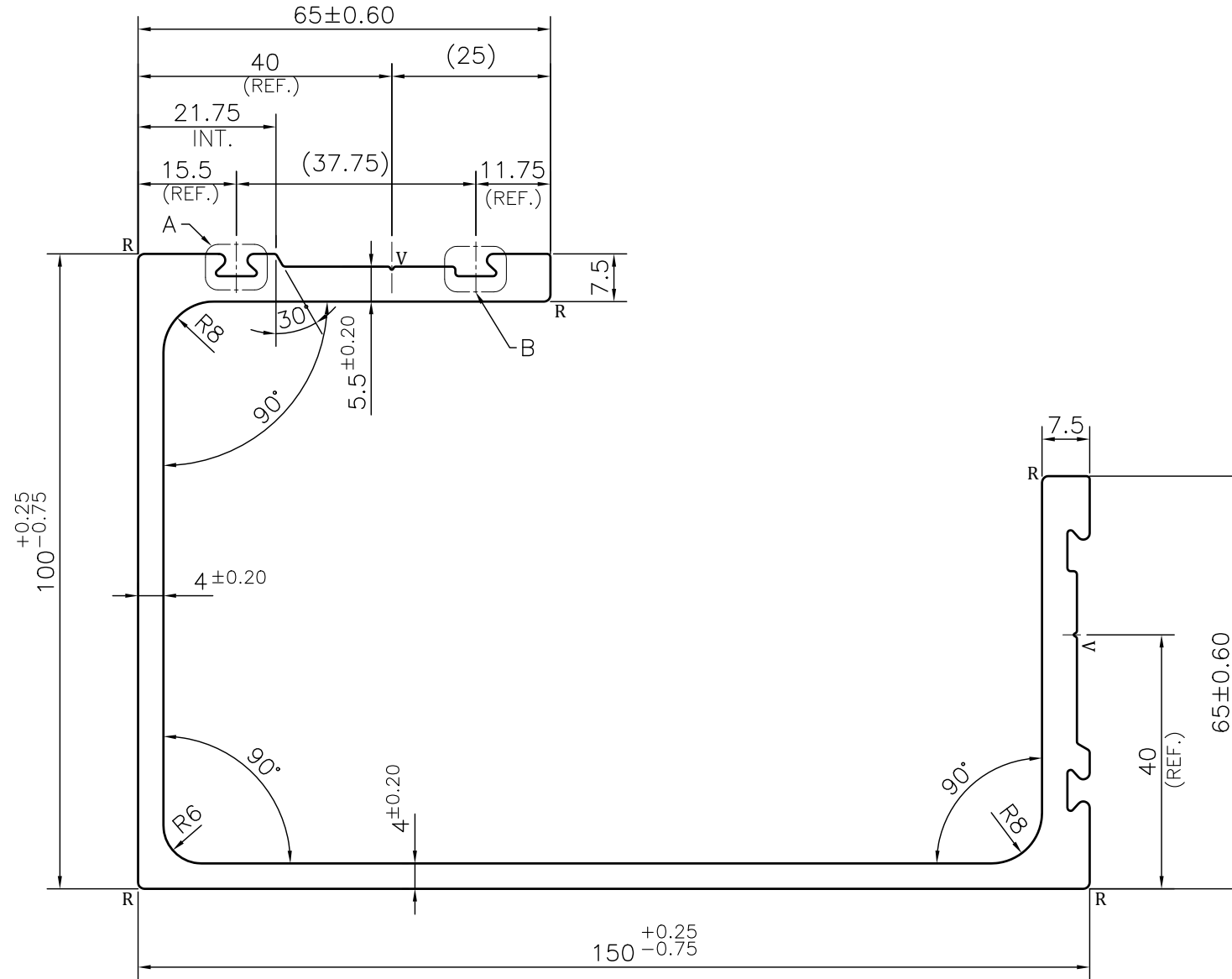

DETAIL B  
SCALE 3:1

NOTE:-

- ROUND OFF ALL SHARP CORNERS WITH 0.50 mm.
- FE:- NOT MORE THAN 0.4%, MG:- 0.8 TO 1.2%
- HARDNESS :- 56HRB
- UTS :- 280 TO 300 MIN MPA

NOTE:-

- R= 1.0 RADIUS (11 PLACES)**
- V= 0.5x60° V-GROOVE (2 PLACES)**

1. STRAIGHTNESS= 1.0mm/M
2. TWIST= 1.0mm/M
3. ANGULARITY= ±1°
4. FLATNESS= ±0.5mm

Q01983

CONTROLLED COPY

 SYMBOL OF QUALITY AN ISO 9001 COMPANY	<b>JINDAL ALUMINIUM LTD.</b> BHIWADI-301019 (INDIA)	NAME	DATE
		DRAWN	ASHUTOSH 11-06-2024
1. ALL DIMENSIONS ARE IN mm. 2. ROUND OFF ALL SHARP CORNERS WITH 0.50 mm. 3. TOLERANCES WILL BE AS PER EN 12020-2, UNLESS OTHERWISE SPECIFIED		CHECKED	PARVESH 04-07-2024
		APPROVED	N.K.HOLEY 04-07-2024
PARTY'S NAME		KNEST MANUFACTURERS LLP, PUNE	
PARTY'S DRAWING No.		AS PER DRAWING	
ALLOY & TEMPER		6061 T6	
DESCRIPTION		FORM WORK SECTION- 150 IC	
SCALE		1:1	
AREA mm <sup>2</sup>		1748.977	
PERIMETER mm.		766.56	
WEIGHT kg/m		4.722	
DRAWING No.		SECTION No.	
P-JAL-B-581-1		7000002617	
X102449		X102449	
PRODUCT CODE:-029			
HSN CODE:- 76042990			