

P-JAL-B-586

X102454

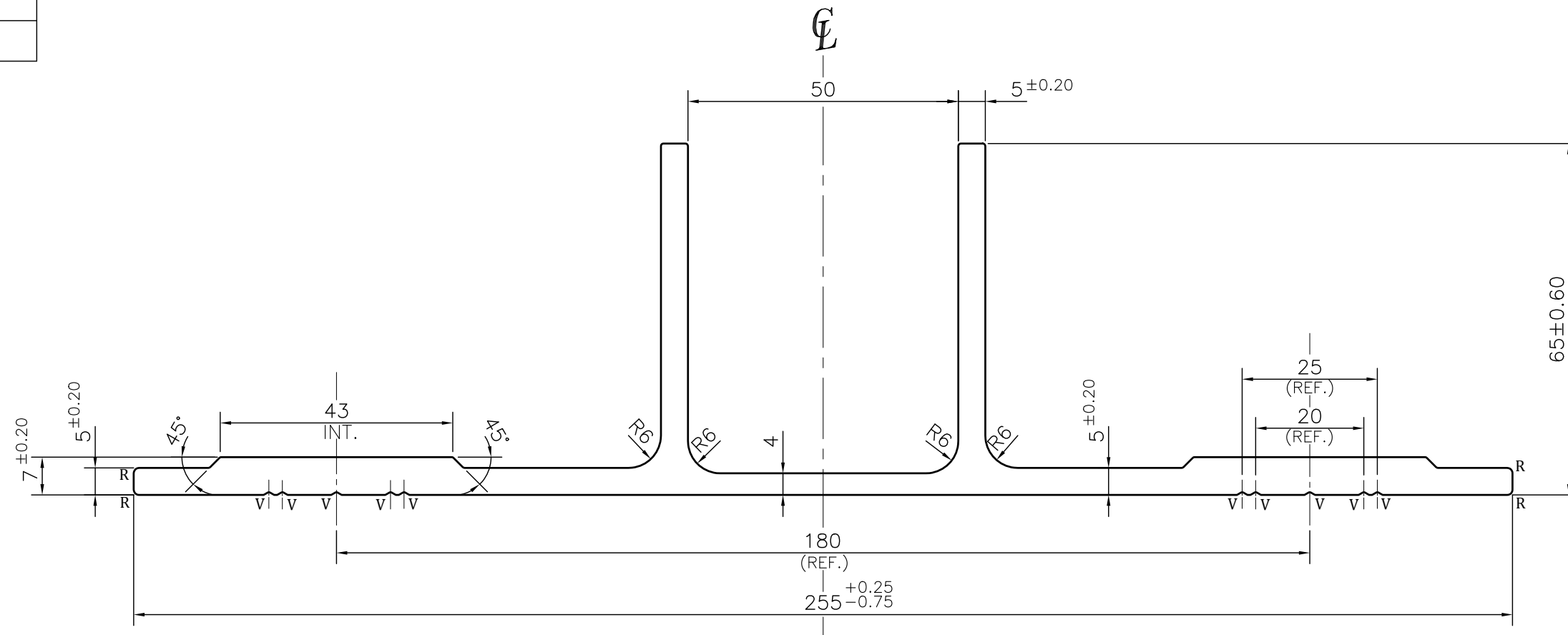

NOTE:-

- ☞ ROUND OFF ALL SHARP CORNERS WITH 0.50 mm.
- ☞ FE:- NOT MORE THAN 0.4%, MG:- 0.8 TO 1.2%
- ☞ HARDNESS :- 56HRB
- ☞ UTS :- 280 TO 300 MIN MPA

**NOTE:-**

- R= 1.0 RADIUS (4 PLACES)**
- V= 0.5x120° V-GROOVE (10 PLACES)**

- 1. STRAIGHTNESS= 1.0mm/M
- 2. TWIST= 1.0mm/M
- 3. ANGULARITY= ±1°
- 4. FLATNESS= ±0.45mm

Q01988

CONTROLLED COPY

 SYMBOL OF QUALITY AN ISO 9001 COMPANY	<b>JINDAL ALUMINIUM LTD.</b> BHIWADI-301019 (INDIA)		NAME	DATE	
			DRAWN	ASHUTOSH	05-06-2024
1. ALL DIMENSIONS ARE IN mm. 2. ROUND OFF ALL SHARP CORNERS WITH 0.50 mm. 3. TOLERANCES WILL BE AS PER EN 12020-2 , UNLESS OTHERWISE SPECIFIED			CHECKED	PARVESH	04-07-2024
			APPROVED	N.K.HOLEY	04-07-2024
PARTY'S NAME KNEST MANUFACTURERS LLP, PUNE			SCALE	1:1	
			AREA mm <sup>2</sup>	2029.417	
PARTY'S DRAWING No. AS PER DRAWING			PERIMETER mm.	754.72	
			WEIGHT kg/m	5.479	
ALLOY & TEMPER 6061 T6			DRAWING No.	SECTION No.	
			P-JAL-B-586	7000002622	
DESCRIPTION FORM WORK SECTION- 155 TO 255 T PROFILE			X102454	X102454	
			PRODUCT CODE:-029		
			HSN CODE:- 76042990		