

P-JAL-B-663-1

X102734

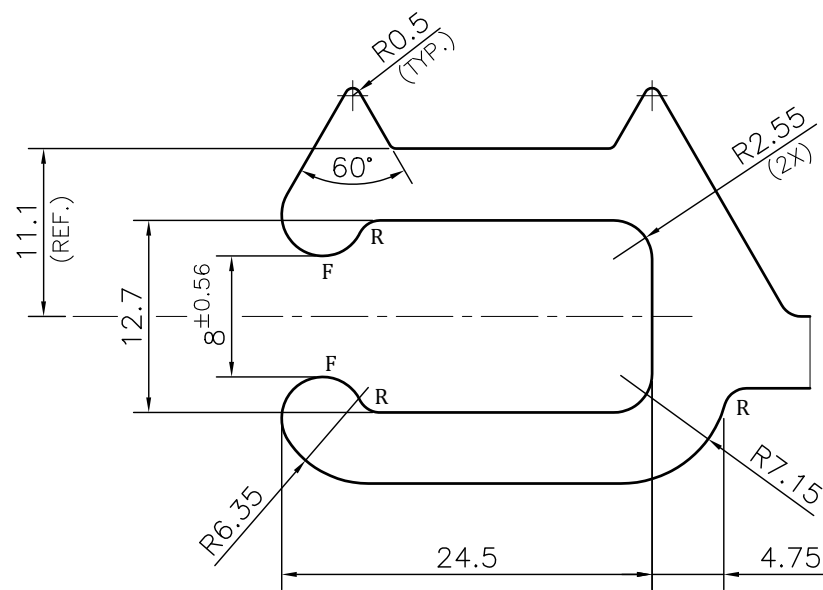

DETAIL A
SCALE 2:1

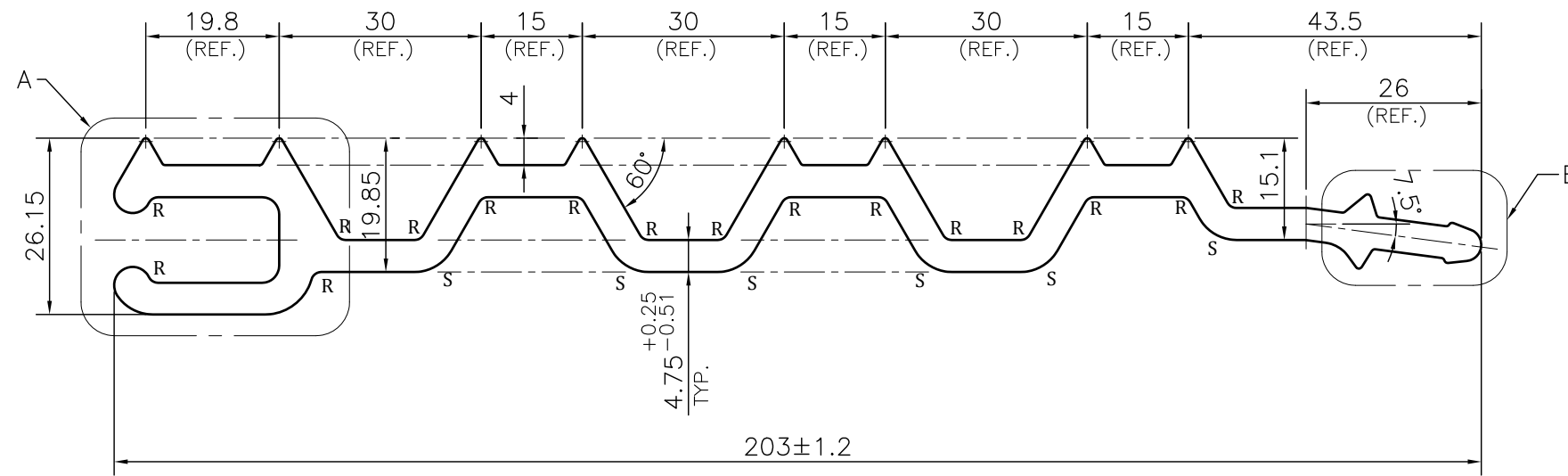
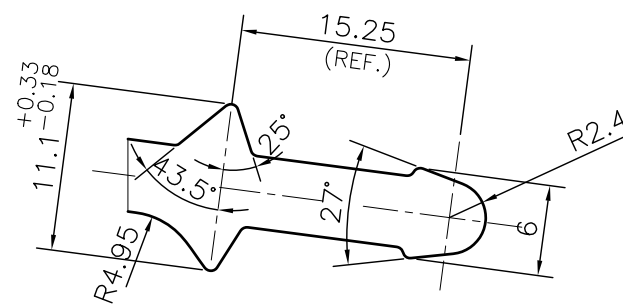

DETAIL B
SCALE 2:1

NOTE:-
R= 1.50 RADIUS (16 PLACES)
S= 6.35 RADIUS (6 PLACES)
F= FULL RADIUS (2 PLACES)

☞ ROUND OFF ALL SHARP CORNERS WITH 0.50 mm.

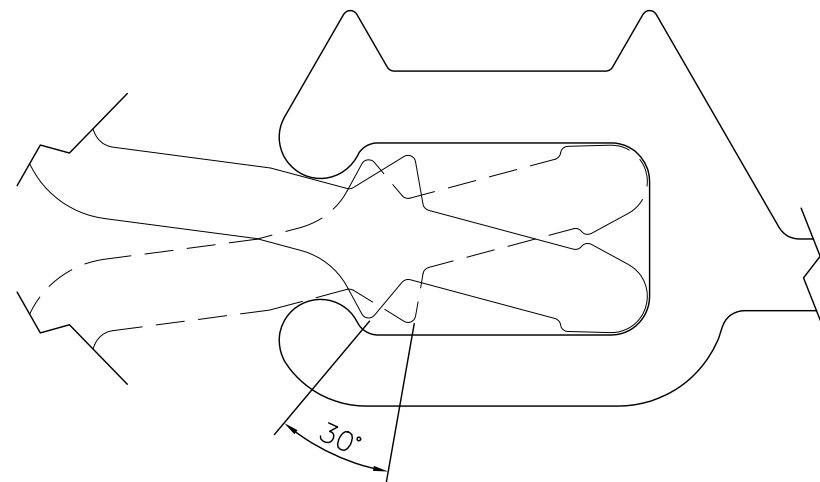

MATCHING
SCALE 2:1

1. STRAIGHTNESS= 1.7mm/M
2. TWIST= 1.7mm/M
3. ANGULARITY= ±2°
4. FLATNESS= 0.007xWIDTH

Q02182

CONTROLLED COPY

 SYMBOL OF QUALITY AN ISO 9001 COMPANY	JINDAL ALUMINIUM LTD. BHIWADI-301019 (INDIA)		NAME	DATE	
			DRAWN	ASHUTOSH	13-08-2024
1. ALL DIMENSIONS ARE IN mm. 2. ROUND OFF ALL SHARP CORNERS WITH 0.50 mm. 3. TOLERANCES WILL BE AS PER BS:EN-755-9 , UNLESS OTHERWISE SPECIFIED			CHECKED	PARVESH	10-09-2024
			APPROVED	J.N.RAI	10-09-2024
PARTY'S NAME GENERAL CATEGORY DELHI MARKET			SCALE		1:1
			AREA mm ²		1447.334
PARTY'S DRAWING No. AS PER DRAWING-SP-790 M			PERIMETER mm.		595.51
			WEIGHT kg/m		3.908
ALLOY & TEMPER HE30 WP			DRAWING No.		SECTION No.
			P-JAL-B-663-1		7000002878
DESCRIPTION ARCHITECTURAL MISC. SECTION			X102734		X102734
			PRODUCT CODE:-056		
		HSN CODE:- 76042990			