

P-6956

X1037

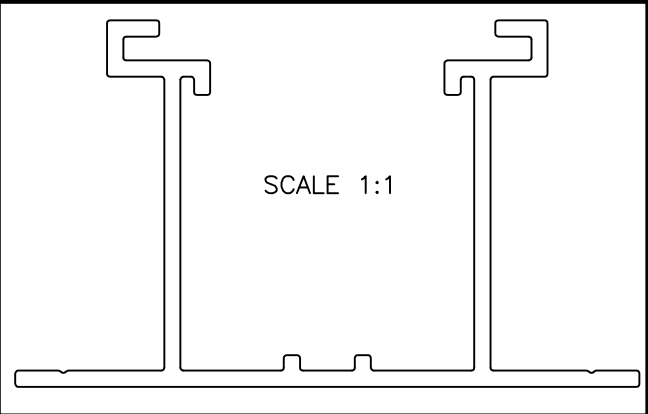

GENERAL WALL THICKNESS = 2.15 mm.

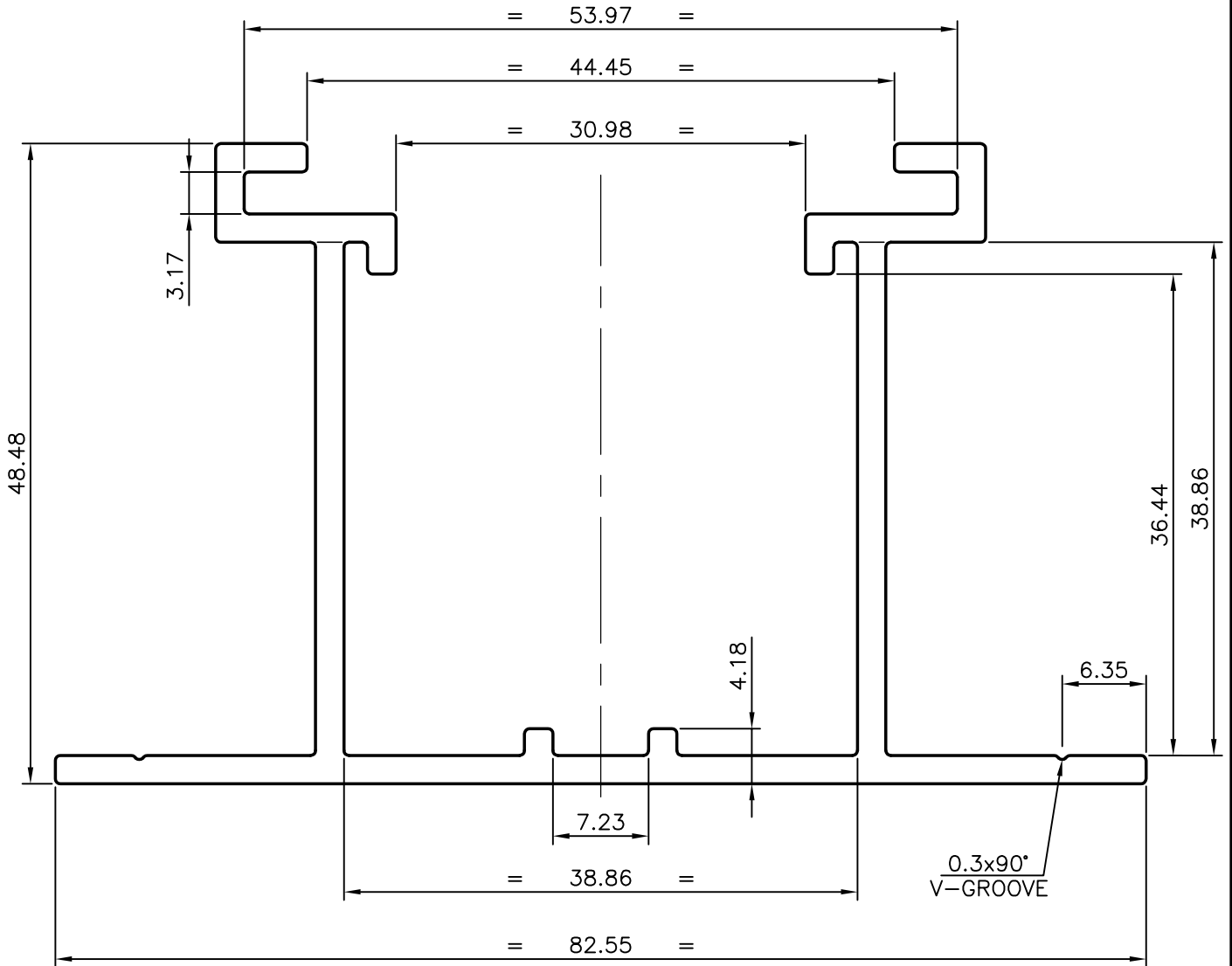

SYMBOL OF QUALITY  
AN ISO 9001 COMPANY

**JINDAL ALUMINIUM LTD.**  
BANGALORE-560073 (INDIA)

	NAME	DATE
DRAWN	PRASANNA.H	11-01-2007
CHECKED		
APPROVED		

1. ALL DIMENSIONS ARE IN mm.
2. ROUND OFF ALL SHARP CORNERS WITH 0.4 mm.
3. TOLERANCES WILL BE AS PER BS:EN-755 UNLESS OTHERWISE SPECIFIED

SCALE	2:1
AREA mm <sup>2</sup>	465.24
PERIMETER mm.	431.382
WEIGHT kg/m	1.256

PARTY'S NAME	PROSOURCE INDUSTRIAL SOLUTION., CANADA
PARTY'S DRAWING No.	SHAPE-4
ALLOY & TEMPER	6063 T54
DESCRIPTION	MISC. SECTION

DRAWING No.	SECTION No.
P-6956	-
X1037	X1037