

P-8721-2

X1050

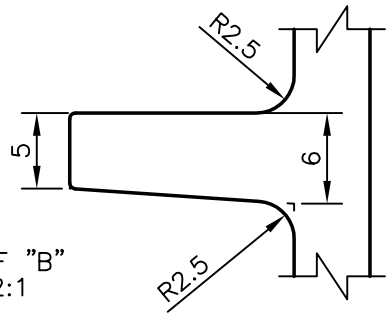

DETAIL OF "B"
SCALE 2:1

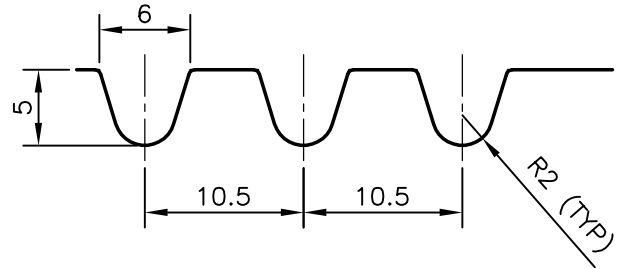

DETAIL OF "A"
SCALE 2:1

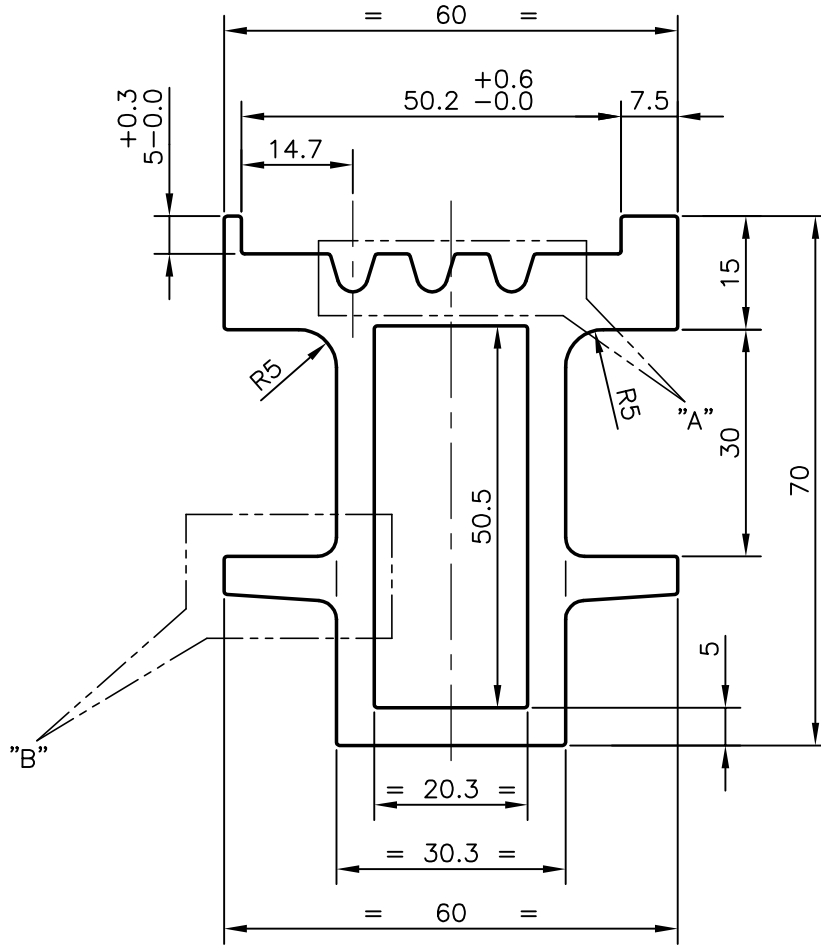

SYMBOL OF QUALITY
AN ISO 9001 COMPANY

JINDAL ALUMINIUM LTD.
BANGALORE-560073 (INDIA)

	NAME	DATE
DRAWN	PRASANNA.H	11-11-2008
CHECKED		
APPROVED		

1. ALL DIMENSIONS ARE IN mm.
2. ROUND OFF ALL SHARP CORNERS WITH 0.4 mm.
3. TOLERANCES WILL BE AS PER IS:6477-1983 UNLESS OTHERWISE SPECIFIED

SCALE	1:1
AREA mm ²	1404.341
PERIMETER mm.	336.113
WEIGHT kg/m	3.792

PARTY'S NAME METAFLEX DOORS INDIA PVT. LTD., NOIDA

DRAWING No. SECTION No.

PARTY'S DRAWING No. 7052

P-8721-2 -

ALLOY & TEMPER HE9 WP

X1050 X1050

DESCRIPTION DOOR SILL PROFILE