

P-8732-1

DETAIL OF "A"  
SCALE 5:1

X1051

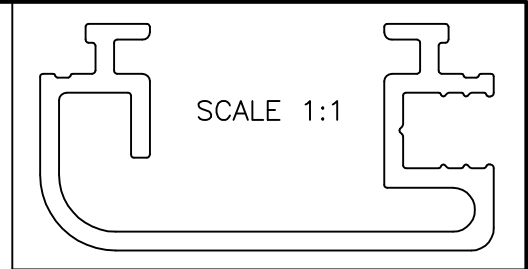
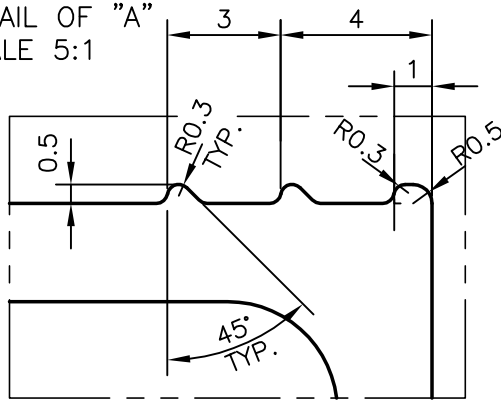

NOTE: -

1. F = FULL RADIUS (1 PLACE)
2. UNSPECIFIED WALL THICKNESS = 2.50 mm

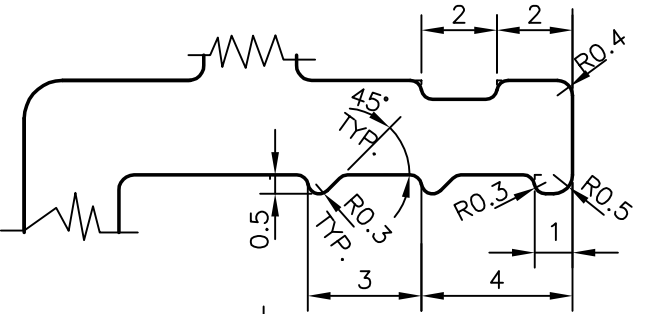

DETAIL OF "B"  
SCALE 5:1

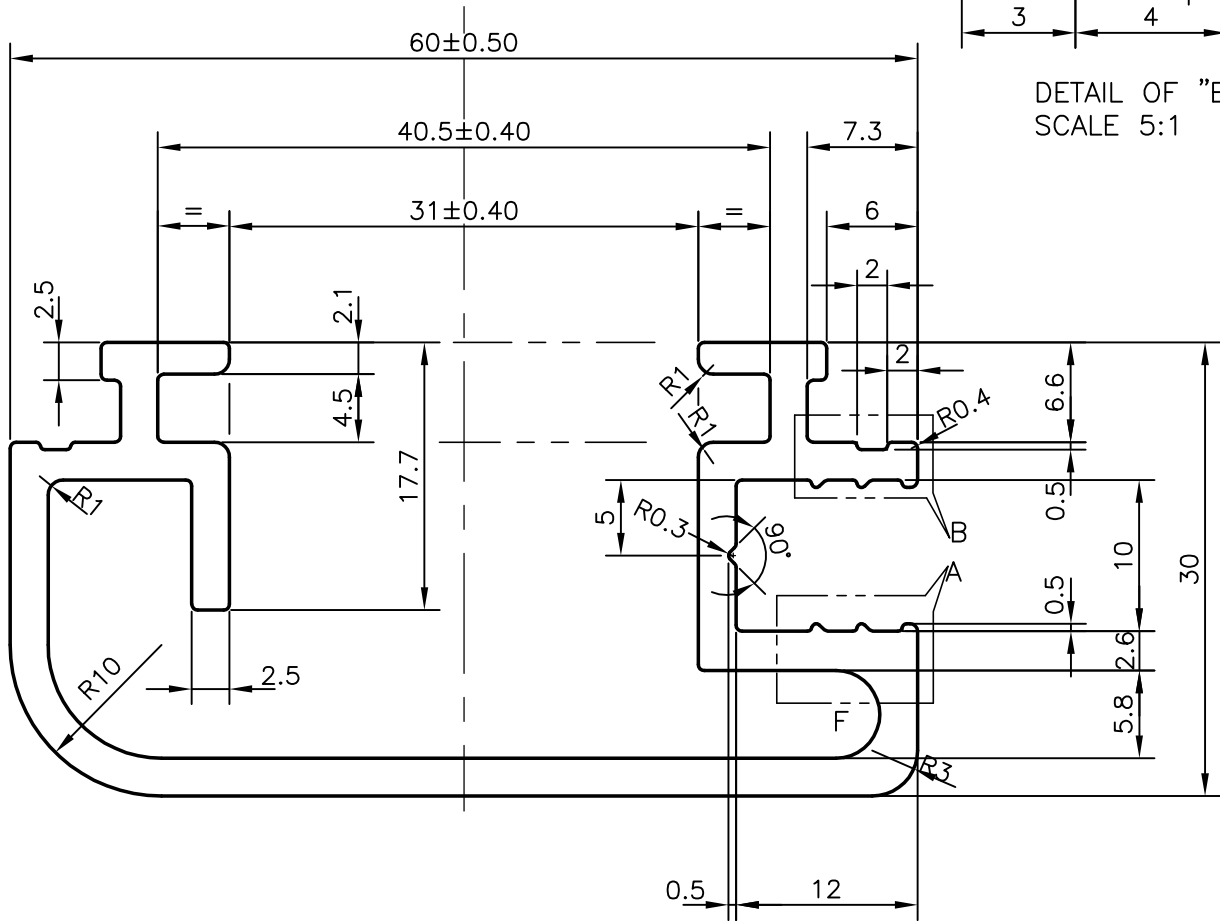

PLEASE NOTE: -

MINIMUM CORNER RADIUS WILL BE 0.30 mm,



SYMBOL OF QUALITY  
AN ISO 9001 COMPANY

**JINDAL ALUMINIUM LTD.**  
BANGALORE-560073 (INDIA)

	NAME	DATE
DRAWN	ABHARANI	05-11-2008
CHECKED		
APPROVED		

1. ALL DIMENSIONS ARE IN mm.
2. ROUND OFF ALL SHARP CORNERS WITH 0.4 mm.
3. TOLERANCES WILL BE AS PER IS:3965-1981 UNLESS OTHERWISE SPECIFIED

SCALE	2:1
AREA mm <sup>2</sup>	417.495
PERIMETER mm.	335.343
WEIGHT kg/m	1.127

PARTY'S NAME: METAFLEX DOORS INDIA PVT. LTD., NOIDA

PARTY'S DRAWING No.: 005.220.04

ALLOY & TEMPER: 6063 T6

DESCRIPTION: DOOR FRAME PROFILE

DRAWING No.	SECTION No.
P-8732-1	-
X1051	X1051
-	-