

P-8733

X1052

DETAIL OF "A"  
SCALE 5:1

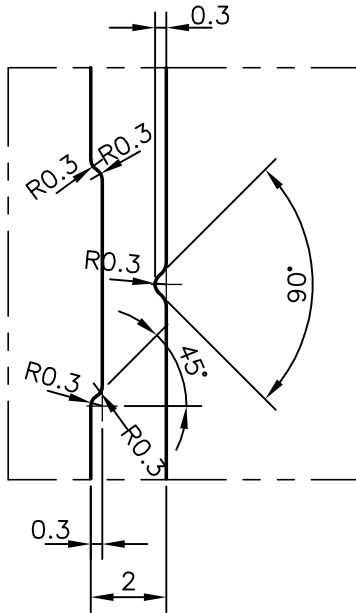

SCALE 1:1

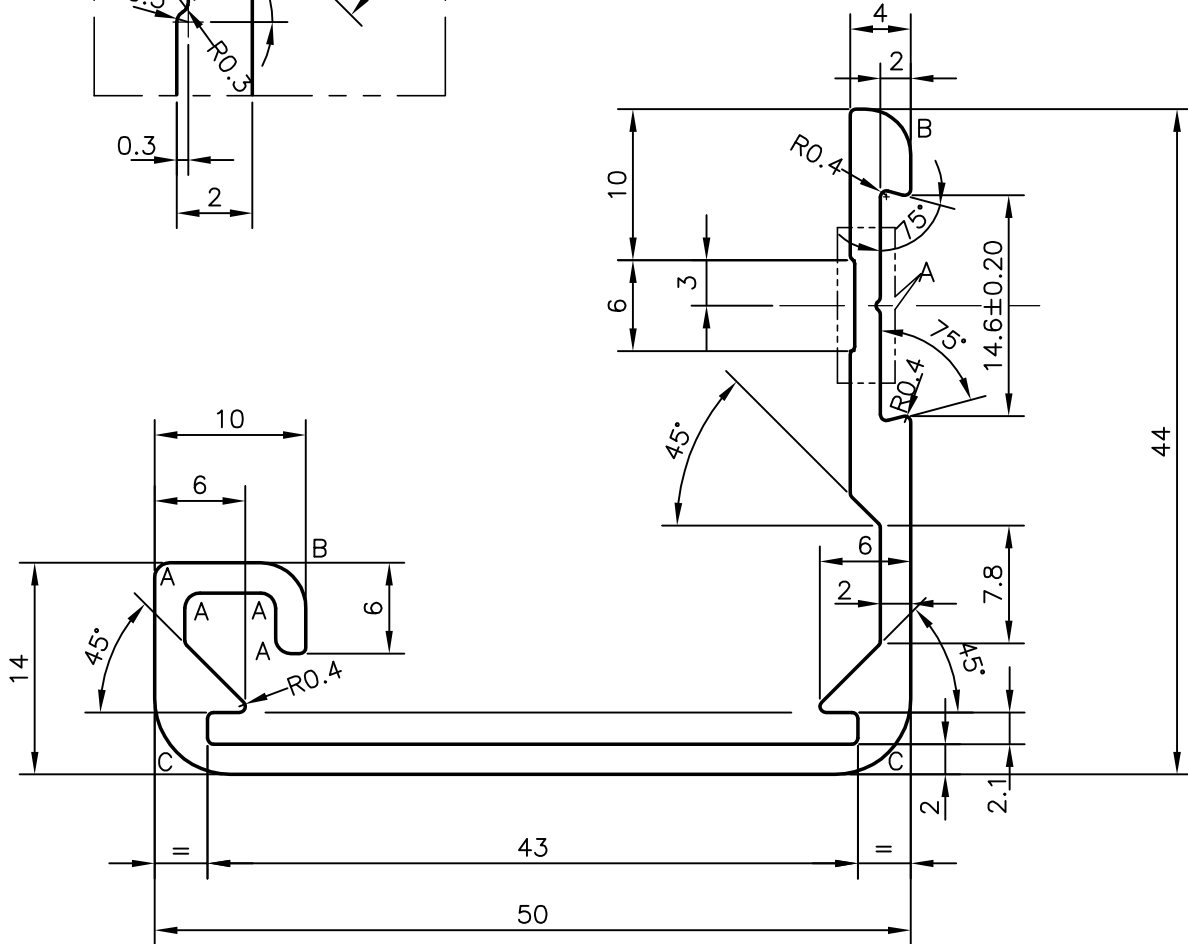
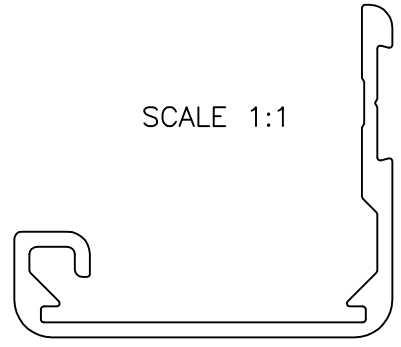

**NOTE:-**

- 1. UNSPECIFIED WALL THICKNESS = 2 mm
- 2. A =RADIUS 1.0 mm(4 PLACES)
- 3. B =RADIUS 3.0 mm(2 PLACES)
- 4. C =RADIUS 5.0 mm(2 PLACES)



SYMBOL OF QUALITY  
AN ISO 9001 COMPANY

**JINDAL ALUMINIUM LTD.**  
BANGALORE-560073 (INDIA)

	NAME	DATE
DRAWN	ABHARANI	22-10-2008
CHECKED		
APPROVED		

SCALE	2:1
AREA mm <sup>2</sup>	265.062
PERIMETER mm.	238.462
WEIGHT kg/m	0.716

DRAWING No.	SECTION No.
P-8733	-
X1052	X1052
-	-

1. ALL DIMENSIONS ARE IN mm. 2. ROUND OFF ALL SHARP CORNERS WITH 0.4 mm. 3. TOLERANCES WILL BE AS PERIS:3965-1981 UNLESS OTHERWISE SPECIFIED	
PARTY'S NAME	METAFLEX DOORS INDIA PVT. LTD.,NOIDA
PARTY'S DRAWING No.	005.222.03
ALLOY & TEMPER	6063 T6
DESCRIPTION	WALL FRAME PROFILE