

P-7378

26821

X1094

DETAIL OF "A"
SCALE 5:1

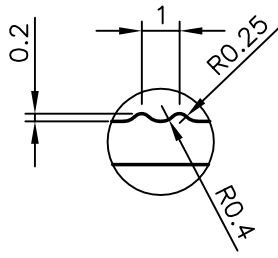

SCALE 1:1

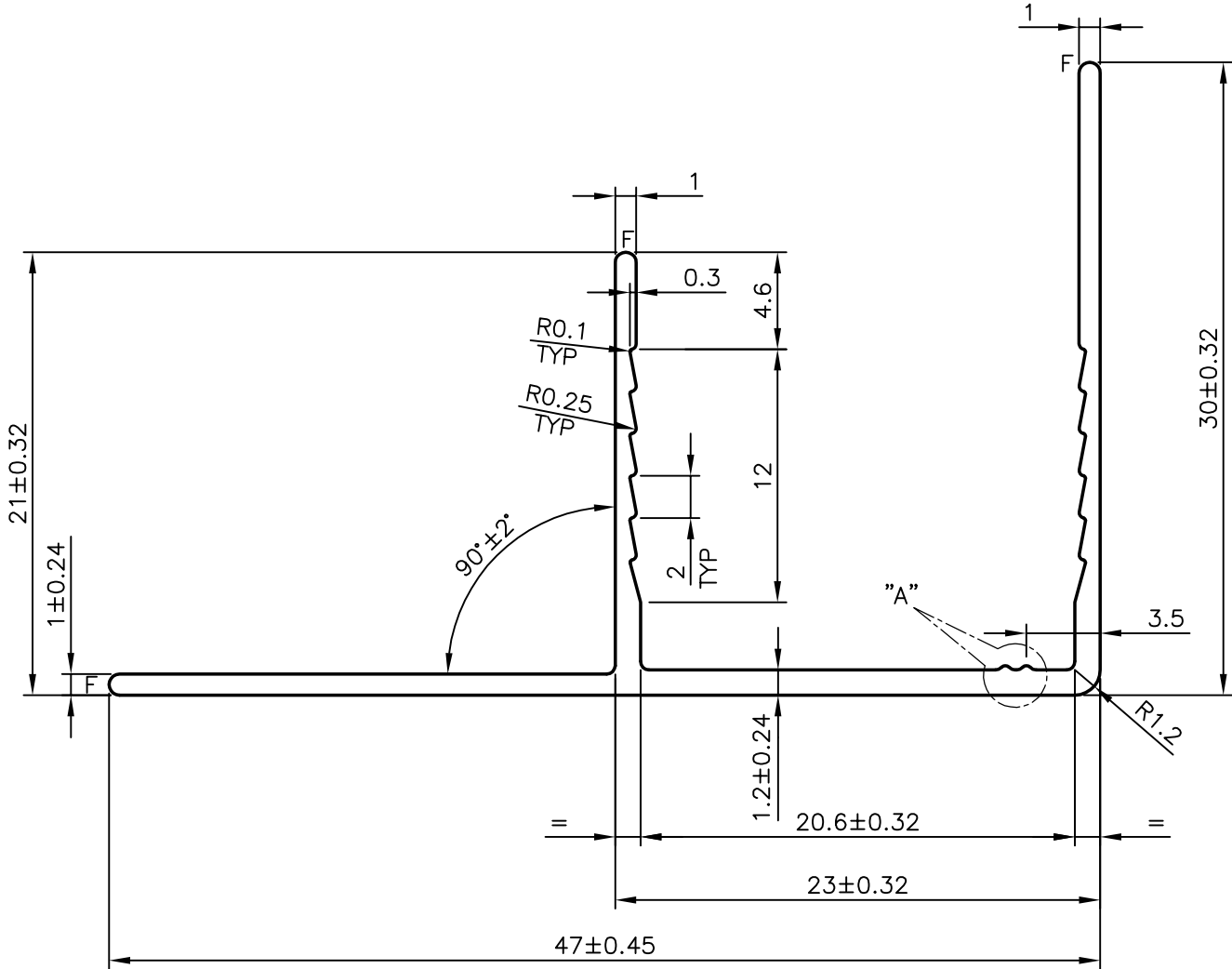

NOTE:-

1. F = FULL RADIUS (3 PLACES)



SYMBOL OF QUALITY
AN ISO 9001 COMPANY

JINDAL ALUMINIUM LTD.
BANGALORE-560073 (INDIA)

	NAME	DATE
DRAWN	PRASANN.H	30-06-2007
CHECKED		
APPROVED		

1. ALL DIMENSIONS ARE IN mm.
2. ROUND OFF ALL SHARP CORNERS WITH 0.40 mm.
3. TOLERANCES WILL BE AS PER BS:EN-755 UNLESS OTHERWISE SPECIFIED

SCALE	3:1
AREA mm ²	97.982
PERIMETER mm.	193.344
WEIGHT kg/m	0.265

PARTY'S NAME	AEROLINK INTERNATIONAL, BANGALORE
PARTY'S DRAWING No.	AS PER DRAWING
ALLOY & TEMPER	6063 T6
DESCRIPTION	MISC. SECTION

DRAWING No.	SECTION No.
P-7378	-
26821	26821
X1094	X1094