

P-8775-1

19421

X1097

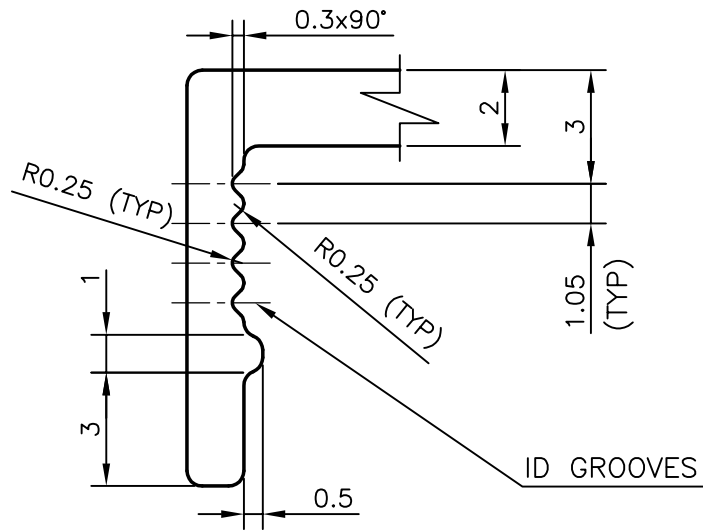

DETAIL OF "A"  
SCALE 5:1

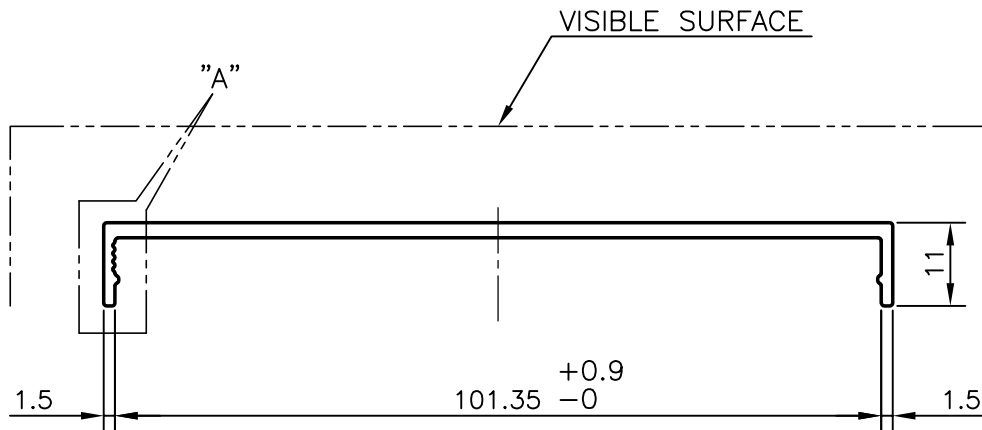

SYMBOL OF QUALITY  
AN ISO 9001 COMPANY

**JINDAL ALUMINIUM LTD.**  
BANGALORE-560073 (INDIA)

	NAME	DATE
DRAWN	PRASANNA.H	06-11-2008
CHECKED		
APPROVED		

1. ALL DIMENSIONS ARE IN mm.
2. ROUND OFF ALL SHARP CORNERS WITH 0.4 mm.
3. TOLERANCES WILL BE AS PER BS:EN-755 UNLESS OTHERWISE SPECIFIED

SCALE	1:1
AREA mm <sup>2</sup>	235.896
PERIMETER mm.	248.979
WEIGHT kg/m	0.637

PARTY'S NAME KOMFORT OFFICE ENVIRONMENTS PLC., U.K.

DRAWING No. SECTION No.

PARTY'S DRAWING No. D4/824/0000-REV-3

P-8775-1 -

ALLOY & TEMPER 6063 T6

19421 19421

X1097 X1097

DESCRIPTION GLAZING CLIP SECTION