

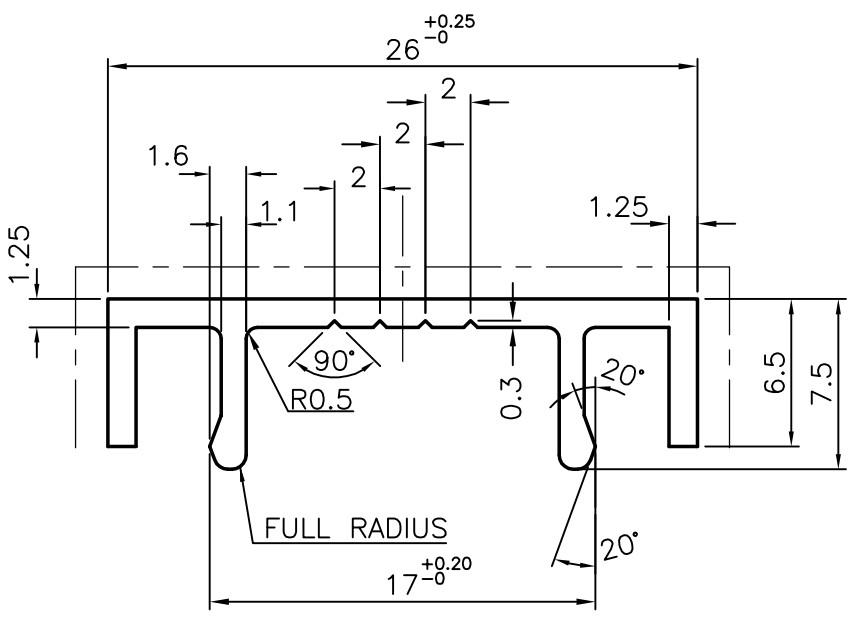

P-1353
8847
12497
20755
X1100

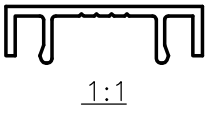

— — — — — DENOTES VISIBLE SURFACE

 SYMBOL OF QUALITY AN ISO 9002 COMPANY	<b>JINDAL ALUMINIUM LTD.</b> <b>BANGALORE-560073 (INDIA)</b>			NAME	DATE
				DRAWN	R.D.SHARMA
1. Tolerances Will Be As Per IS : 3965-1981, UNLESS OTHERWISE SPECIFIED 2. All Dimensions Are in mm. 3. Round off All Sharp Corners with 0.4R				CHECKED	
				APPROVED	
				SCALE	3:1
PARTY'S NAME	KOMFORT SYSTEMS LTD., U.K			WEIGHT kg/m	0.162
PARTY'S DRAWING No.	D4/863/0000	FINISH	-	SECTION No.	X1100
ALLOY & TEMPER	HE9WP	LENGTH:	2700 mm & 3000	DRAWING No.	
DESCRIPTION	COVER TRIM			X1100	