

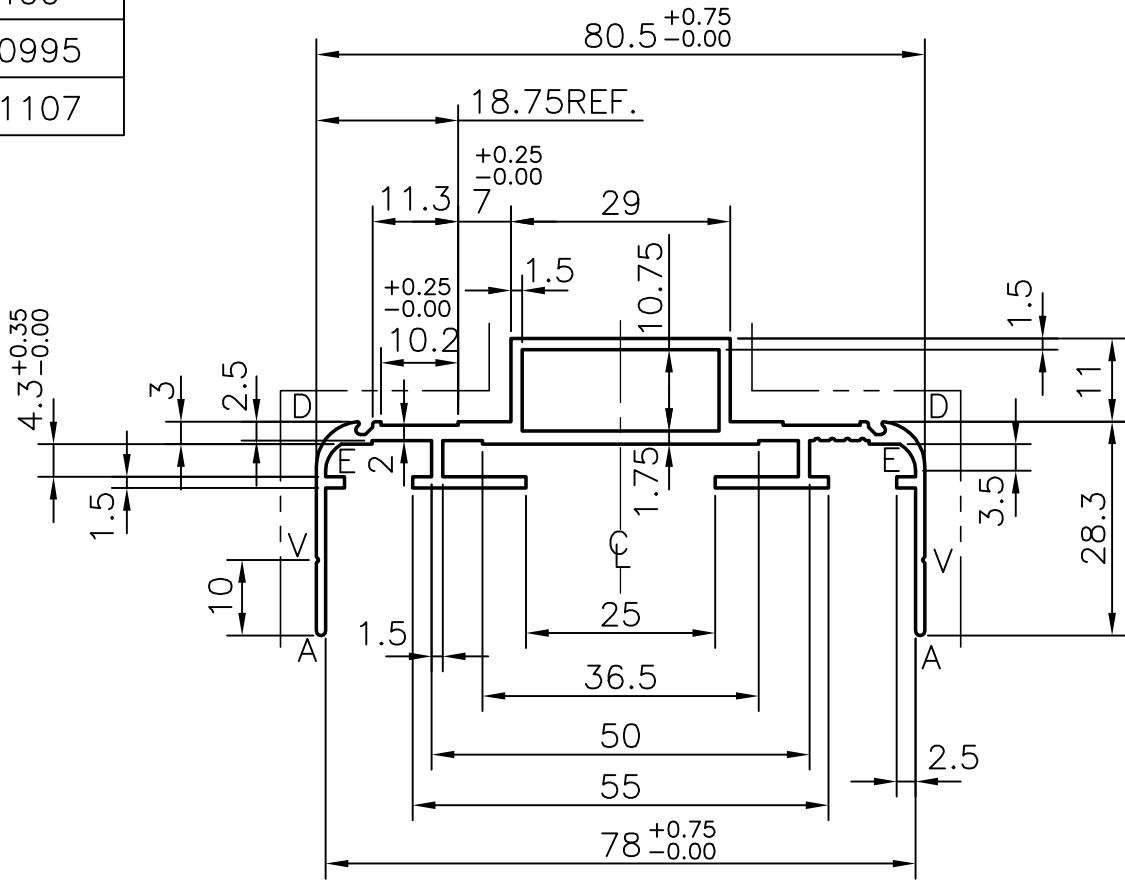

P-4183  
 9400  
 20995  
 X1107

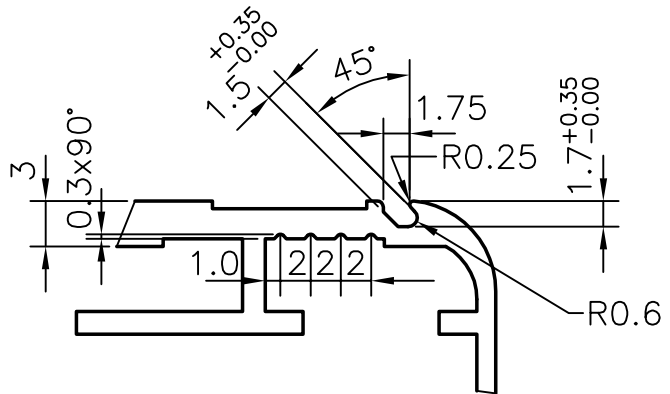

A = FULL RADIUS (2)  
 V = 0.30x90° GROOVE (2)  
 D = 6.0 RADIUS (2)  
 E = 4.0 RADIUS (2)  
 ----- EXPOSED SURFACE



|  |  |                      |                     |
|--|--|----------------------|---------------------|
| <br>SYMBOL OF QUALITY<br>AN ISO 9002 COMPANY                      | <b>JINDAL ALUMINIUM LTD.</b><br>BANGALORE-560073 (INDIA) | NAME                 | DATE                |
|  |  | DRAWN                | R.D.Sharma 26-03-03 |
|  |  | CHECKED              |                     |
| 1. ALL DIMENSIONS ARE IN mm.<br>2. ROUND OFF ALL SHARP CORNERS WITH 0.40 mm.<br>3. TOLERANCES WILL BE AS PER BS 1474-1987 UNLESS OTHERWISE SPECIFIED |  | APPROVED             |                     |
| PARTY'S NAME   | KOMFORT OFFICE ENVIRONMENTS PLC., U.K.                   | SCALE                | 1:1 & 2:1           |
| PARTY'S DRAWING No.  | D3/M22D/0000 (ISSUE-2)                                   | AREA mm <sup>2</sup> | 368.1               |
| ALLOY & TEMPER   | 6063 TF  | PERIMETER mm.        | 381.9               |
| DESCRIPTION  | MIRAGE GLAZING LINER DOUBLE GLAZED                       | WEIGHT kg/m          | 0.994               |
|  |  | SECTION No.          | X1107               |
|  |  | DRAWING No.          | X1107               |