

P-4333-1
 9403
 20998
 X1109

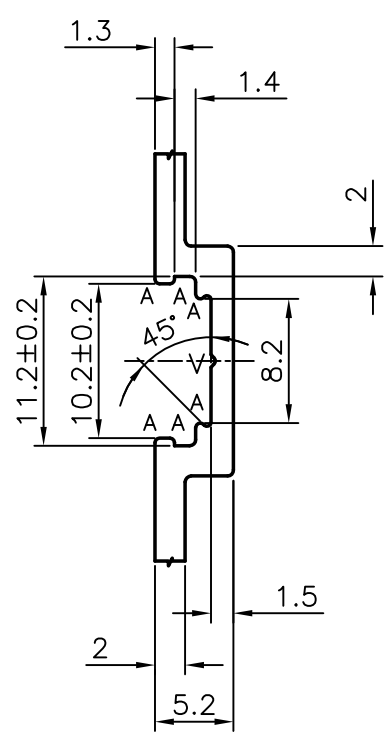

A=0.3 RAD
 V=GROOVE 0.3x90°
 --- =VISIBLE FACES

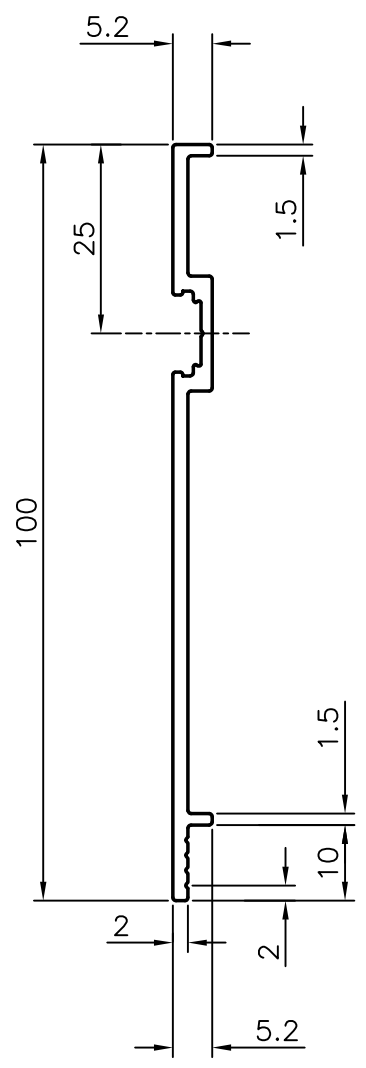
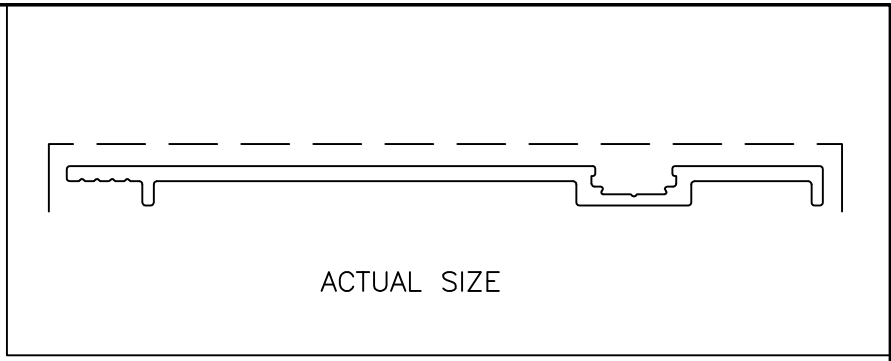
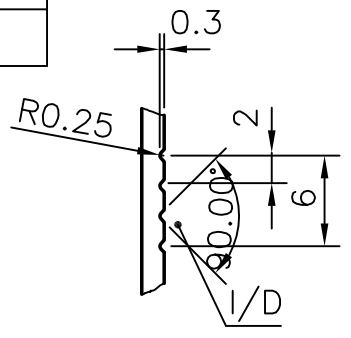

JINDAL ALUMINIUM LTD.
 BANGALORE-560073 (INDIA)

| | NAME | DATE |
|----------|------------|------------|
| DRAWN | MALINGAPPA | 23.07.2003 |
| CHECKED | | |
| APPROVED | | |

1. ALL DIMENSIONS ARE IN mm.
2. ROUND OFF ALL SHARP CORNERS WITH 0.40 mm.
3. TOLERANCES WILL BE AS PER BS: 1474-1987 UNLESS OTHERWISE SPECIFIED

| | |
|----------------------|---------|
| SCALE | 1:1/2:1 |
| AREA mm ² | 220 |
| PERIMETER mm. | 230.58 |
| WEIGHT kg/m | 0.594 |

| | |
|--------------|---|
| PARTY'S NAME | KOMFORT OFFICE ENVIRONMENTS PLC UNITED KINGDOM |
|--------------|---|

| DRAWING No. | SECTION No. |
|-------------|-------------|
| P-4333 | - |
| 9403 | 9403 |
| 20998 | 20998 |
| X1109 | X1109 |

| | |
|---------------------|----------|
| PARTY'S DRAWING No. | D4/TF292 |
|---------------------|----------|

| | |
|----------------|---------|
| ALLOY & TEMPER | 6063-T6 |
|----------------|---------|

| | |
|-------------|----------------|
| DESCRIPTION | 100mm SKIRTING |
|-------------|----------------|