

P-4338-1

9405

21000

X1111

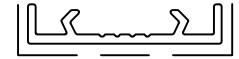

ACTUAL SIZE

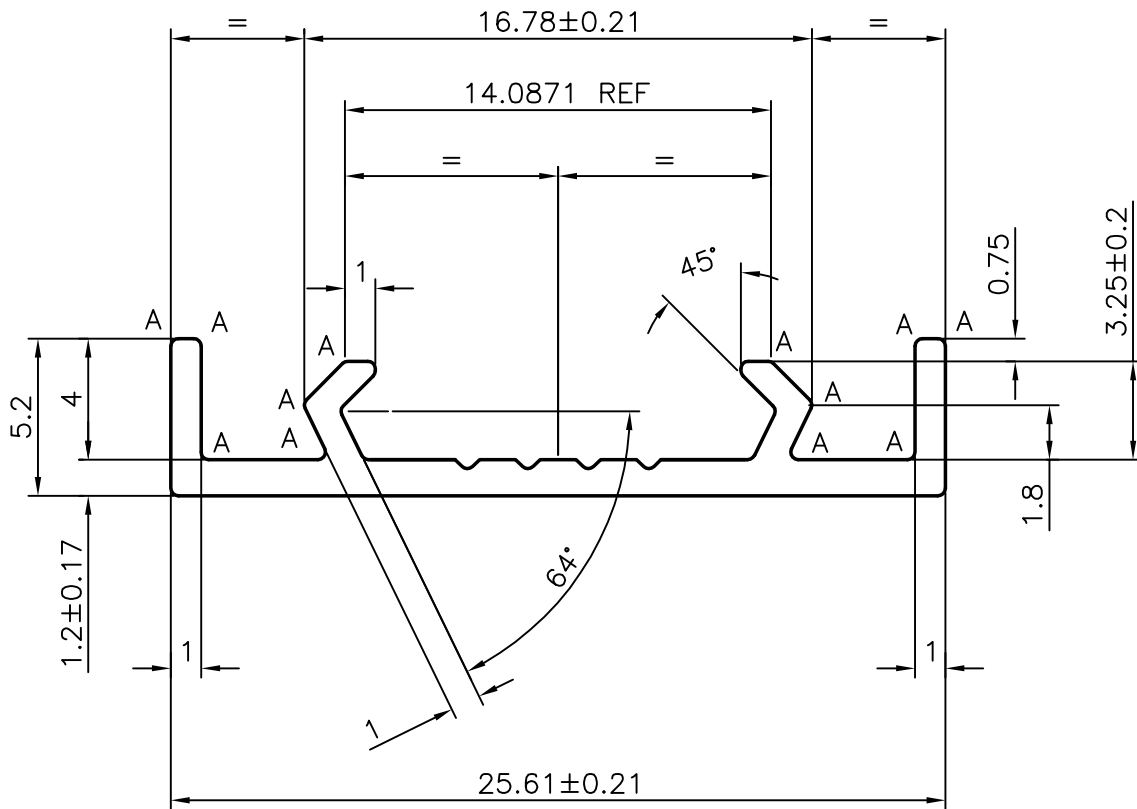
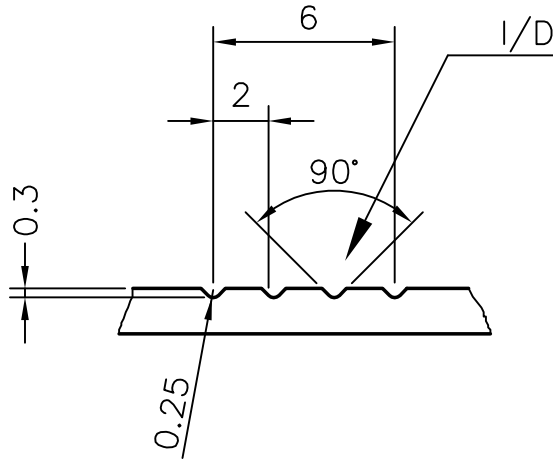

A = RAD 0.25
 --- = VISIBLE FACES



SYMBOL OF QUALITY
 AN ISO 9002 COMPANY

JINDAL ALUMINIUM LTD.
 BANGALORE-560073 (INDIA)

	NAME	DATE
DRAWN	MALINGAPPA	23.07.2003
CHECKED		
APPROVED		

1. ALL DIMENSIONS ARE IN mm.
2. ROUND OFF ALL SHARP CORNERS WITH 0.40 mm.
3. TOLERANCES WILL BE AS PER BS: 1474-1987 UNLESS OTHERWISE SPECIFIED

SCALE	1:1/4:1
AREA mm ²	46.10
PERIMETER mm.	84.28
WEIGHT kg/m	0.124

PARTY'S NAME	KOMFORT OFFICE ENVIRONMENTS PLC UNITED KINGDOM
PARTY'S DRAWING No.	D4/TF274
ALLOY & TEMPER	6063-T6
DESCRIPTION	HUNG PANEL STRIP

DRAWING No.	SECTION No.
P-4338-1	-
9405	9405
21000	21000
X1111	X1111