

P-4573-2

19015

21025

X1117

ID DETAIL
SCALE 5:1

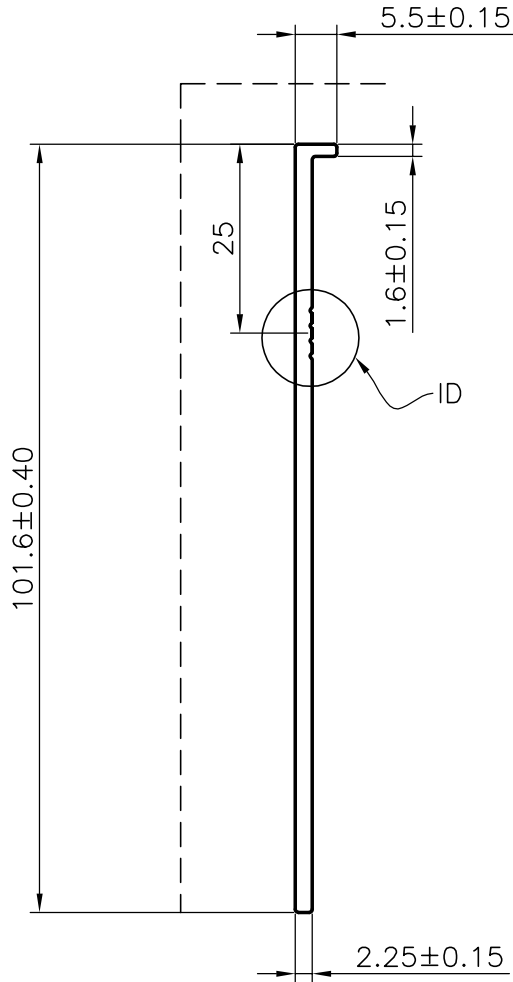
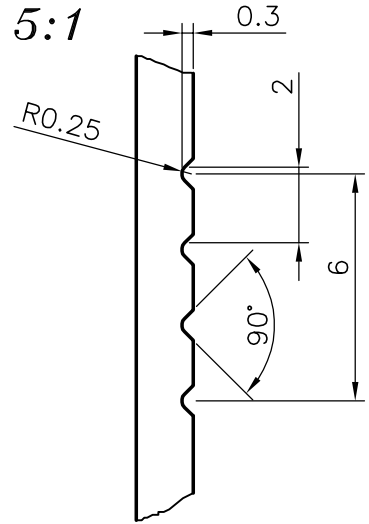

----- DENOTES VISIBLE SURFACE



SYMBOL OF QUALITY
AN ISO 9001 COMPANY

JINDAL ALUMINIUM LTD.
BANGALORE-560073 (INDIA)

	NAME	DATE
DRAWN	RAGHAVENDRA	10-12-2003
CHECKED		
APPROVED		
SCALE		1:1
AREA	mm ²	233.20
PERIMETER	mm.	215.40
WEIGHT	kg/m	0.629
DRAWING No.	SECTION No.	
P-4573-2	-	
19015	19015	
21025	21025	
X1117	X1117	

1. ALL DIMENSIONS ARE IN mm.
2. ROUND OFF ALL SHARP CORNERS WITH 0.40 mm.
3. TOLERANCES WILL BE AS PER BS: 1474-1987 UNLESS OTHERWISE SPECIFIED

PARTY'S NAME	KOMFORT OFFICE ENVIRONMENTS PLC UNITED KINGDOM
PARTY'S DRAWING No.	AS PER DRAWING (D4/613/0000/ISSUE-4)
ALLOY & TEMPER	6063 TF
DESCRIPTION	100mm ALI SKIRTING