

P-3988  
8274  
22295  
X1137

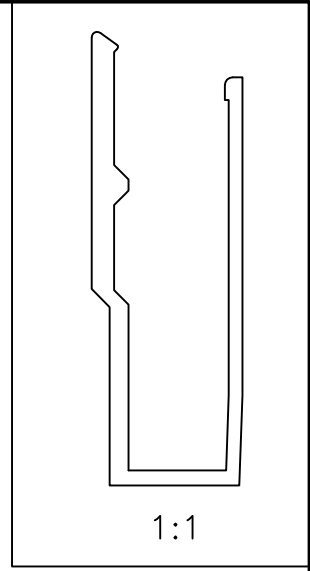
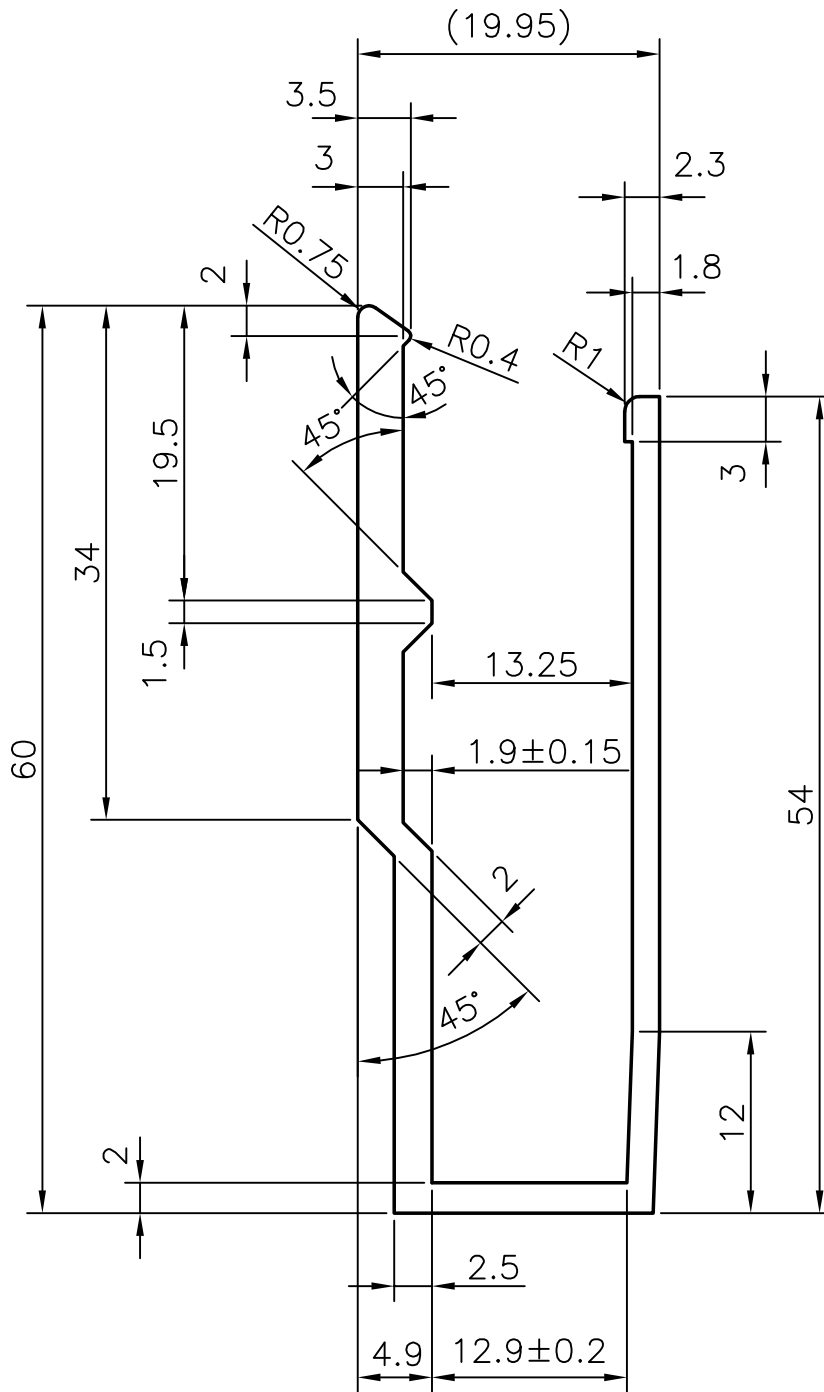

**JINDAL ALUMINIUM LTD.**  
BANGALORE-560073 (INDIA)

	NAME	DATE
DRAWN	R.D.Sharma	26-09-02
CHECKED		
APPROVED		

1. ALL DIMENSIONS ARE IN mm.
2. ROUND OFF ALL SHARP CORNERS WITH 0.40 mm.
3. TOLERANCES WILL BE AS PER BS 1474-1987 UNLESS OTHERWISE SPECIFIED

PARTY'S NAME	KOMFORT OFFICE ENVIRONMENTS PLC., U.K.
PARTY'S DRAWING No.	D4/832/0000 (ISSUE-2)
ALLOY & TEMPER	6063 TF
DESCRIPTION	SKIRTING CLIP

SCALE	2:1
AREA mm <sup>2</sup>	297.3
PERIMETER mm.	261.9
WEIGHT kg/m	0.803
SECTION No.	X1137
DRAWING No.	X1137