

P-4186-2
8294
22306
X1138

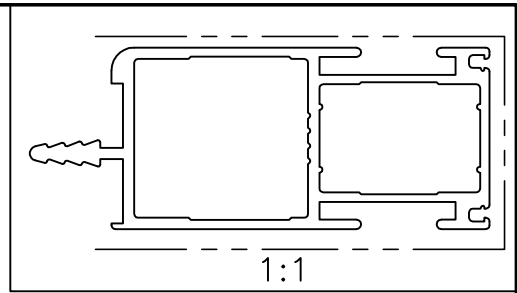

F = FULL RADIUS (5)
T = 0.50 RADIUS (19)
D = 3.0 RADIUS (1)
----- EXPOSED SURFACE

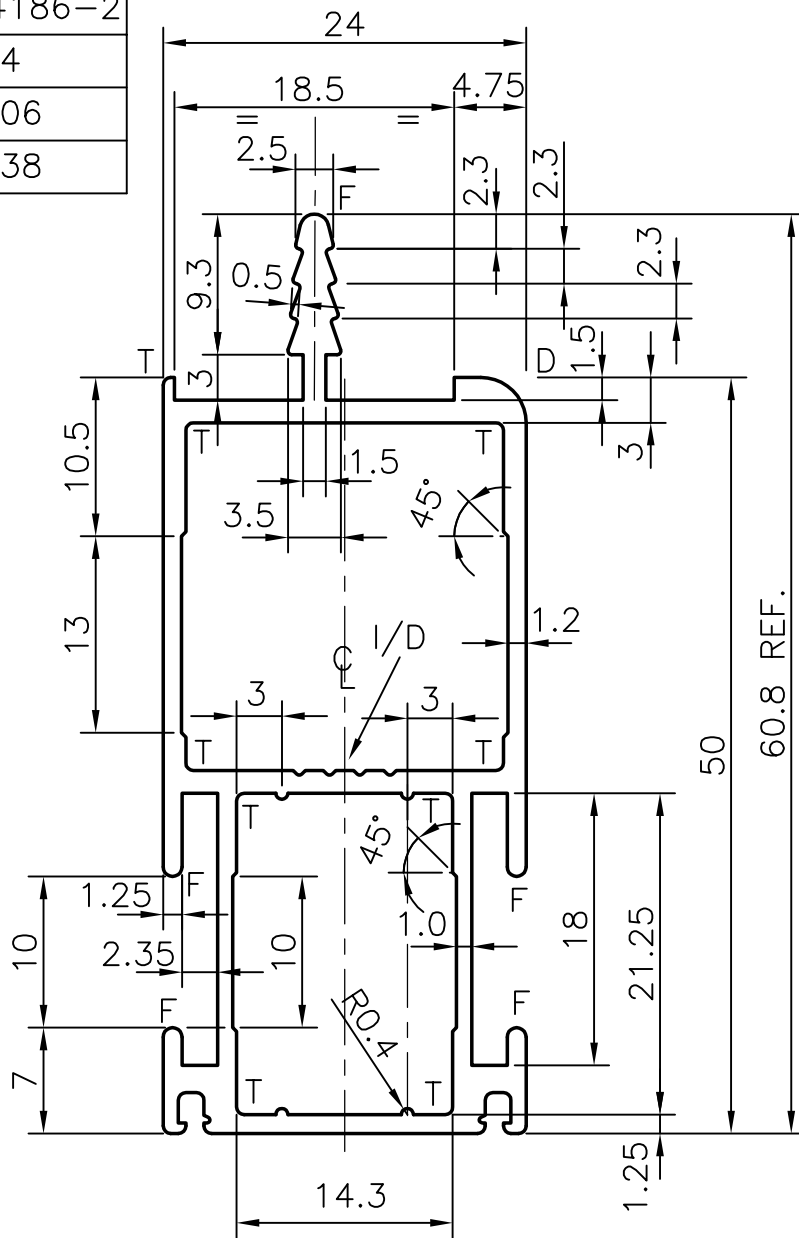
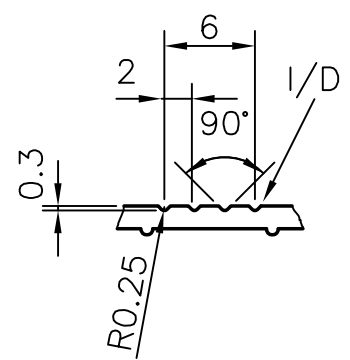
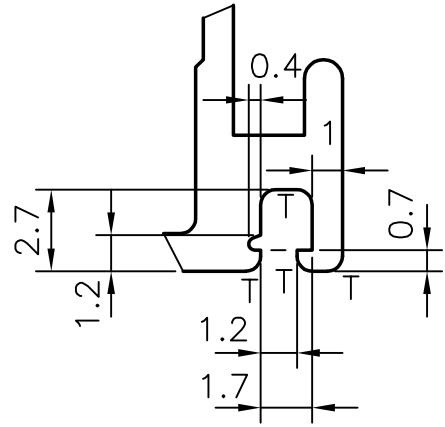

1. UNSPECIFIED WALL THICKNESS:- 1.50 mm.
2. SHARP CORNERS NOT POSSIBLE



SYMBOL OF QUALITY
AN ISO 9002 COMPANY

JINDAL ALUMINIUM LTD.
BANGALORE-560073 (INDIA)

	NAME	DATE
DRAWN	R.D.Sharma	23-04-03
CHECKED		
APPROVED		

1. ALL DIMENSIONS ARE IN mm.
2. ROUND OFF ALL SHARP CORNERS WITH 0.40 mm.
3. TOLERANCES WILL BE AS PER BS 1474-1987 UNLESS OTHERWISE SPECIFIED

PARTY'S NAME	KOMFORT OFFICE ENVIRONMENTS PLC., U.K.
PARTY'S DRAWING No.	WS/P253 (ISSUE-12)
ALLOY & TEMPER	6063 TF
DESCRIPTION	MAIN BEAM

SCALE	1:1,2:1&4:1
AREA mm ²	278.7
PERIMETER mm.	233.7
WEIGHT kg/m	0.753
SECTION No.	X1138
DRAWING No.	X1138