

P-4188-1

8295

22307

X1139

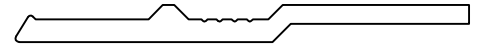

1:1

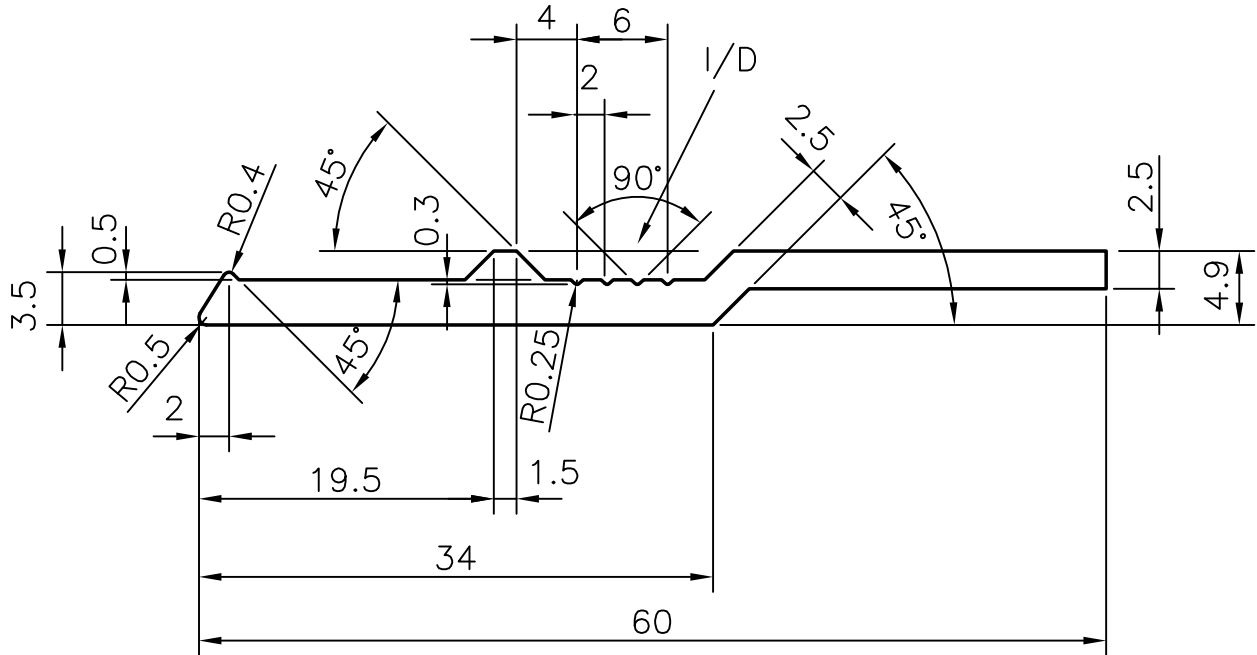

SYMBOL OF QUALITY
AN ISO 9002 COMPANY

JINDAL ALUMINIUM LTD.
BANGALORE-560073 (INDIA)

	NAME	DATE
DRAWN	R.D.Sharma	23-04-03
CHECKED		
APPROVED		

1. ALL DIMENSIONS ARE IN mm.
2. ROUND OFF ALL SHARP CORNERS WITH 0.40 mm.
3. TOLERANCES WILL BE AS PER BS 1474-1987 UNLESS OTHERWISE SPECIFIED

SCALE	2:1
AREA mm ²	173.6
PERIMETER mm.	128.9

PARTY'S NAME	KOMFORT OFFICE ENVIRONMENTS PLC., U.K.	WEIGHT kg/m	0.469
PARTY'S DRAWING No.	D4/829/0000 (ISSUE-3)	SECTION No.	X1139
ALLOY & TEMPER	6063 TF	DRAWING No.	X1139
DESCRIPTION	'MASONARY' SKIRTING CLIP		