

P-5676-2

22362

X1142

EXPOSED SURFACE

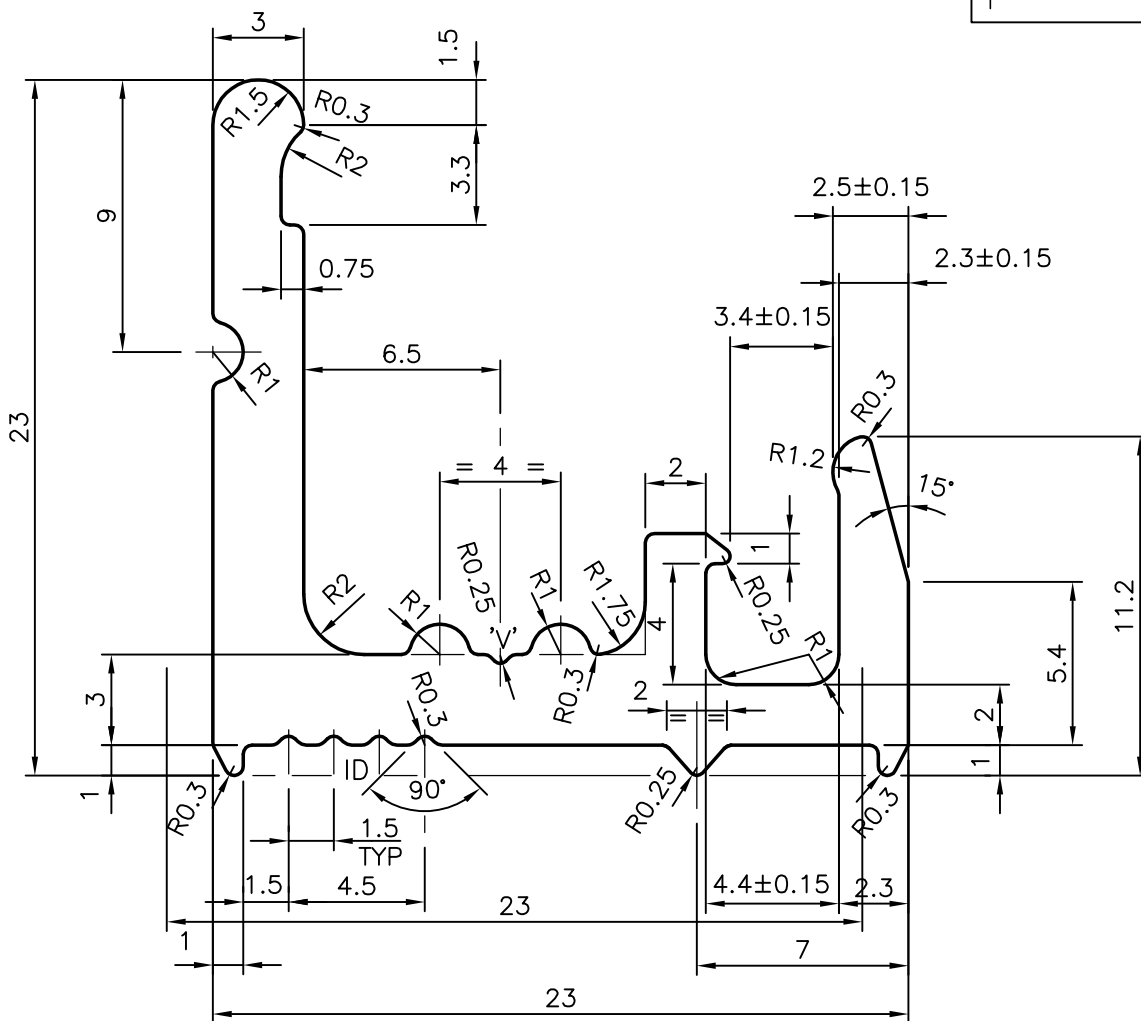
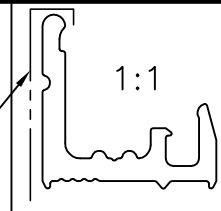

'V' = VEE GROOVE 0.3x90°xR0.25 (1 PLACE)
 ID = VEE GROOVE 4NO. 0.30x90°xR0.3

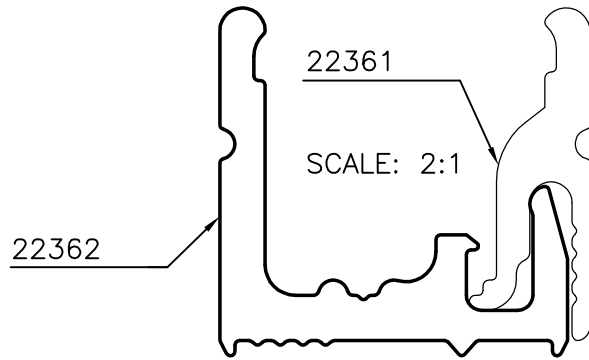

 SYMBOL OF QUALITY AN ISO 9001 COMPANY	JINDAL ALUMINIUM LTD. BANGALORE-560073 (INDIA)	NAME	DATE
		DRAWN	MALINGAPPA 06-09-2005
		CHECKED	
1. ALL DIMENSIONS ARE IN mm. 2. ROUND OFF ALL SHARP CORNERS WITH 0.40 mm. 3. TOLERANCES WILL BE AS PER BS:1474-1987 UNLESS OTHERWISE SPECIFIED		APPROVED	
		SCALE	4:1
		AREA mm ²	145.933
PARTY'S NAME		PERIMETER mm.	117.997
		WEIGHT kg/m	0.394
PARTY'S DRAWING No.		DRAWING No.	SECTION No.
		P-5676-2	-
ALLOY & TEMPER		22362	22362
		X1142	X1142
DESCRIPTION			
BASE CHANNEL Pt. 1 (SJ2)			