

P-9097-1

X1151

X1151

19234

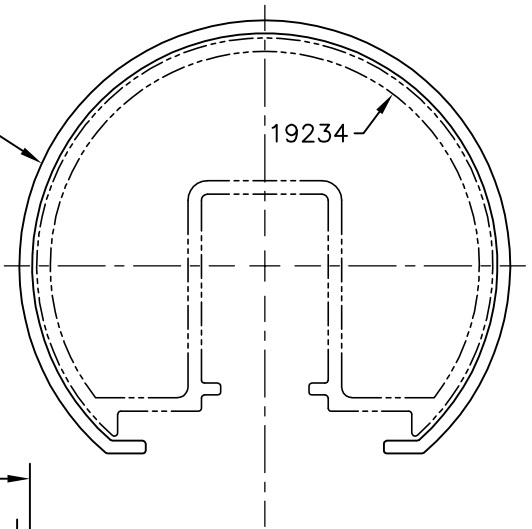
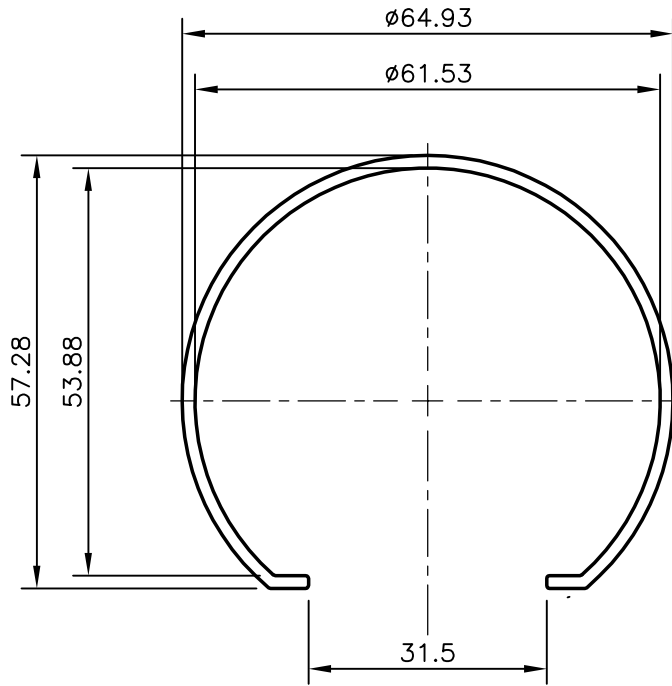

PLEASE CONFIRM ALL THE DIMENSIONS AND MATCH WITH YOUR MATCHING COMPONENT

PLEASE SPECIFY THE EXPOSED SURFACE IN THE DRAWING WHEREVER BETTER FINISH REQUIRED.

 SYMBOL OF QUALITY AN ISO 9001 COMPANY	JINDAL ALUMINIUM LTD. BANGALORE-560073 (INDIA)	NAME	DATE
		DRAWN	J.P.KAUSHIK 06-03-2009
		CHECKED	
		APPROVED	
1. ALL DIMENSIONS ARE IN mm. 2. ROUND OFF ALL SHARP CORNERS WITH 0.40 mm. 3. TOLERANCES WILL BE AS PER BS:EN-755 UNLESS OTHERWISE SPECIFIED		SCALE	1:1
		AREA mm ²	277.74
		PERIMETER mm.	329.574
PARTY'S NAME PROSOURCE INDUSTRIAL SOLUTIONS, CANADA		WEIGHT kg/m	0.750
		DRAWING No.	SECTION No.
PARTY'S DRAWING No. AS PER SKETCH		P-9097-1	-
		X1151	X1151
ALLOY & TEMPER 6063 T5			
DESCRIPTION MISC. SECTION			