

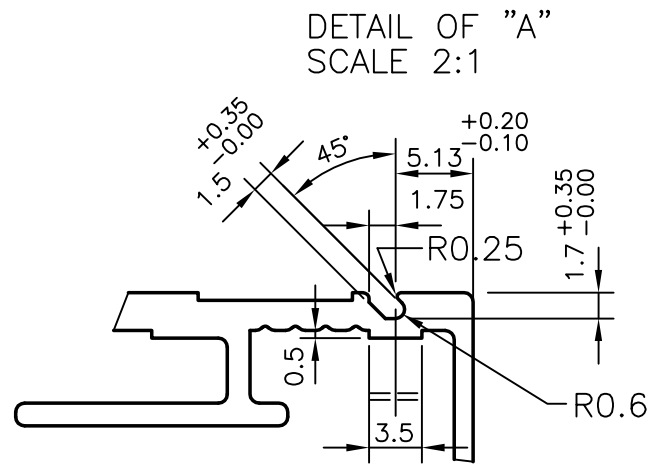

P-9084-1
X1152
-

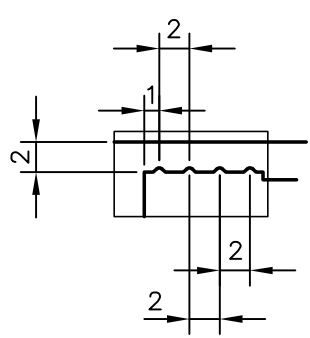
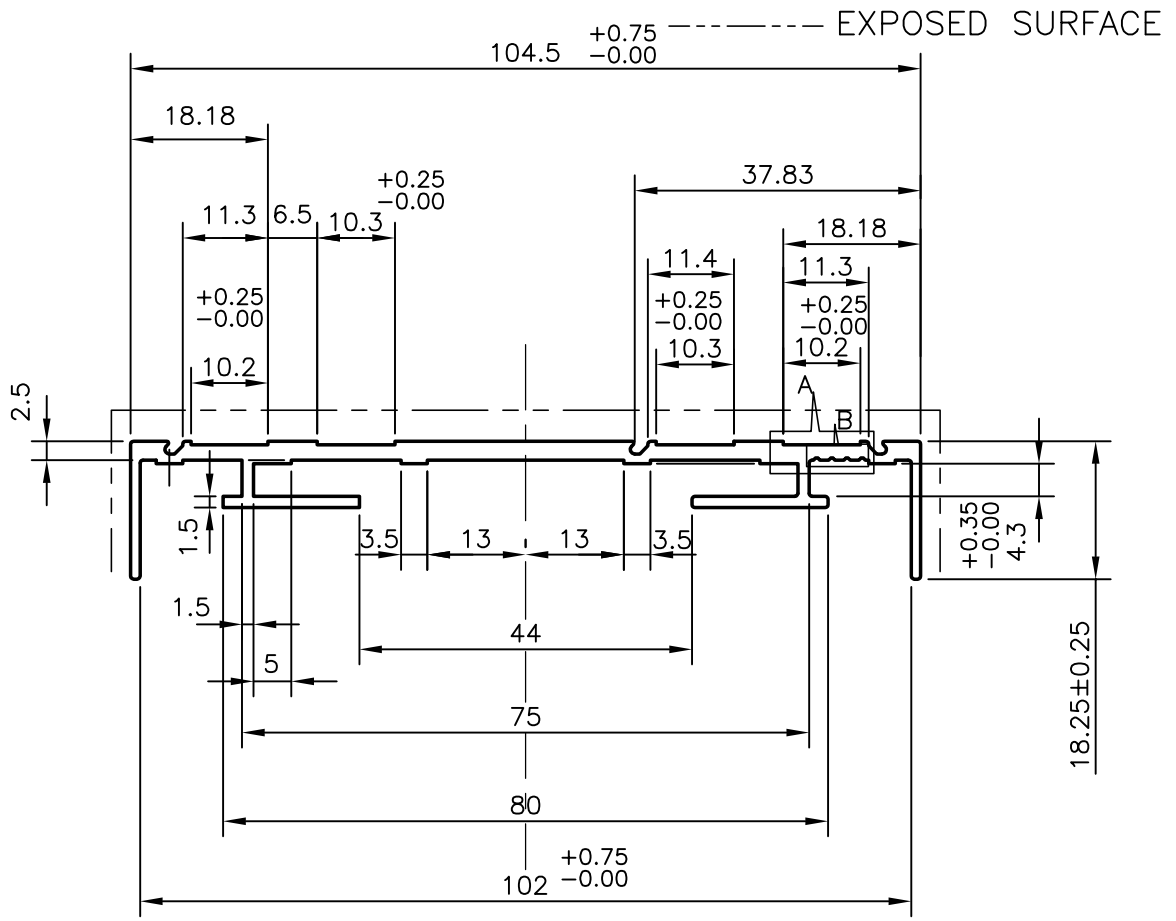

V = 0.30x90° GROOVE (4)

 SYMBOL OF QUALITY AN ISO 9001 COMPANY	JINDAL ALUMINIUM LTD. BANGALORE-560073 (INDIA)	NAME	DATE
		DRAWN	J.P.KAUSHIK 05-03-2009
1. ALL DIMENSIONS ARE IN mm. 2. ROUND OFF ALL SHARP CORNERS WITH 0.4 mm. 3. TOLERANCES WILL BE AS PER BS:EN-755 UNLESS OTHERWISE SPECIFIED		CHECKED	
		APPROVED	
PARTY'S NAME KOMFORT OFFICE ENVIRONMENTS PLC., U.K.		SCALE	1:1
		AREA mm ²	350.519
PARTY'S DRAWING No. D3/824B/0000 (ISSUE-3)		PERIMETER mm.	383.233
		WEIGHT kg/m	0.946
ALLOY & TEMPER 6063 T6		DRAWING No.	SECTION No.
		P-9084-1	
DESCRIPTION KOMFIRE WINDOW LINERE		X1152	X1152