

P-9086-1
X1154
-

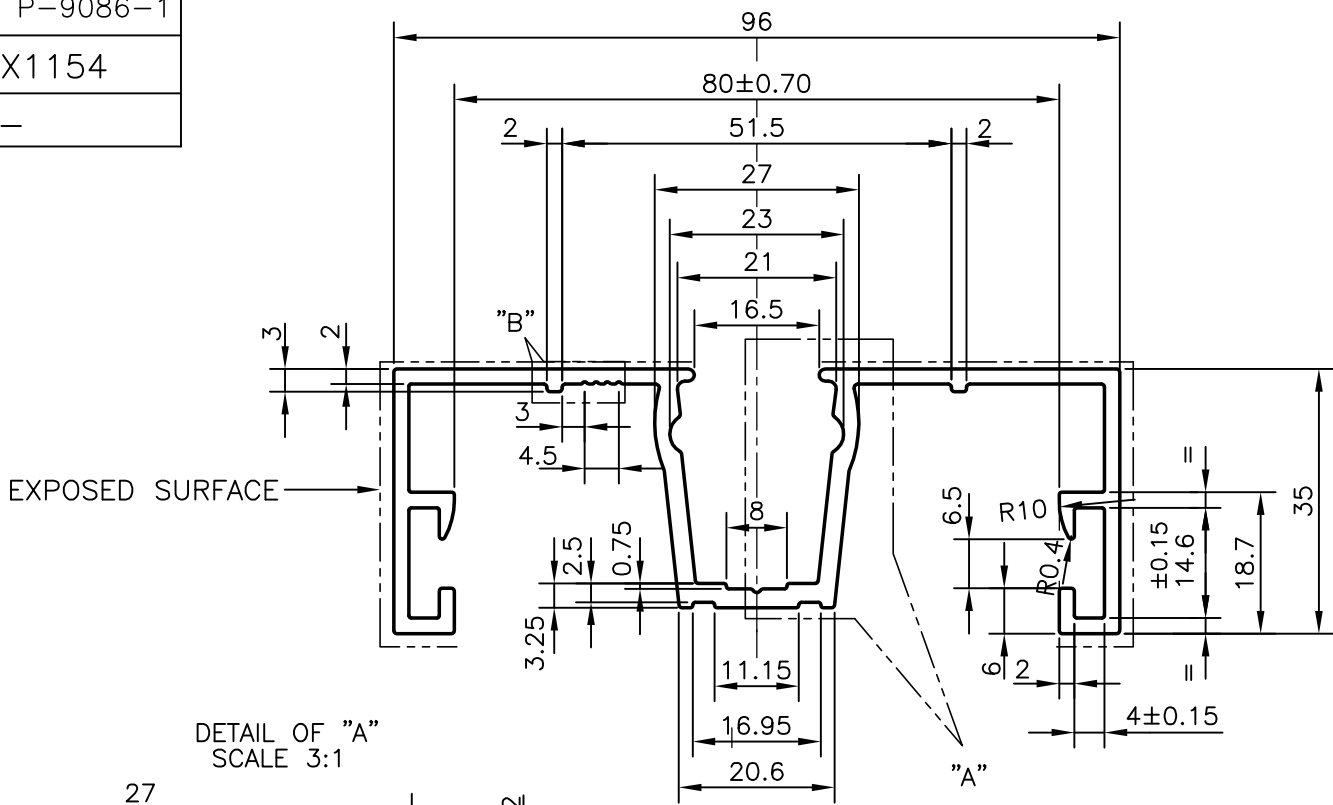

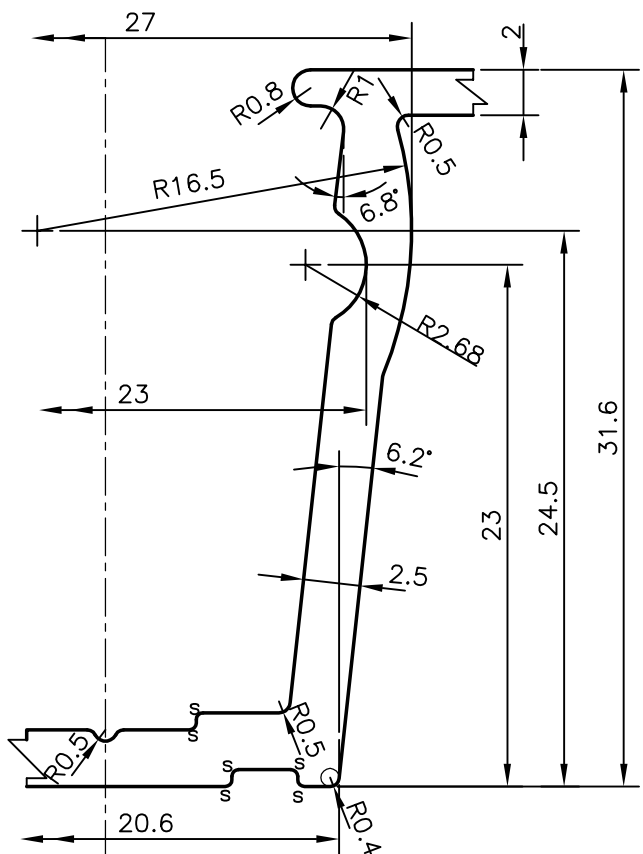

DETAIL OF "A"
SCALE 3:1

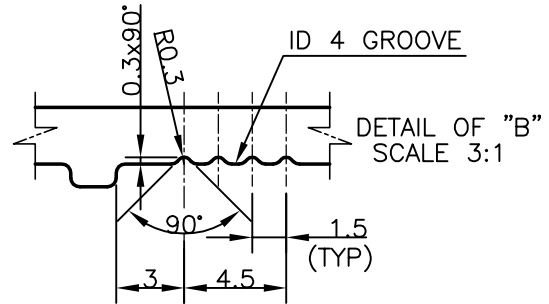

NOTE:-

- 1. UNSPECIFIED WALL THICKNESS = 2.0 mm
- 3. s = R0.30 mm (12 PLACES)



 SYMBOL OF QUALITY AN ISO 9001 COMPANY	JINDAL ALUMINIUM LTD. BANGALORE-560073 (INDIA)	NAME	DATE
		DRAWN	J.P.KAUSHIK 09-04-2009
		CHECKED	
1. ALL DIMENSIONS ARE IN mm. 2. ROUND OFF ALL SHARP CORNERS WITH 0.4 mm. 3. TOLERANCES WILL BE AS PER BS:EN-755 UNLESS OTHERWISE SPECIFIED		APPROVED	
PARTY'S NAME	KOMFORT OFFICE ENVIRONMENTS PLC., U.K.	SCALE	1:1
PARTY'S DRAWING No.	D4-SJ75-R (ISSUE-1)	AREA mm ²	561.312
ALLOY & TEMPER	6063 T6	PERIMETER mm.	523.58
DESCRIPTION	75 mm GLAZING POCKET	WEIGHT kg/m	1.516
		DRAWING No.	SECTION No.
		P-9086-1	
		X1154	X1154(ISSUE-3)